

Screw Driven automation tables

Precise multi-axis positioning systems play an integral part in today's semiconductor, computer peripheral, solar power, flat panel, life sciences, lab automation, biomedical and electronics industries. The demands for tighter specifications, improved throughput and consistent quality have become increasingly stringent. Because of the complexity associated with these systems, many manufacturers insist on a single source supplier to eliminate multiple vendor design incompatibilities and delivery conflicts. With over forty years' experience as a global leader in the development of products and technology, Parker provides the most advanced, easy to integrate high-precision electromechanical systems.

Contents

30-33	Overview
34-63	400XR Series Precision Linear Positioners
64-69	XRS Cartesian Systems
70-79	402/403XE Series Positioners
80-89	404XE Series Positioners
90-111	HD Series Industrial Linear Positioners
112-127	Ultra Series Precision Stages
128-133	100CT & 800CT Series Tables
134-137	200RT Series Rotary Tables
138-141	R Series Worm Drive Rotary Tables
142-145	ZP200 Series Vertical Lift "Wedge" Table
146-150	Additional Products



天津昕科佳业科技有限公司

地址：天津市红桥区咸阳北路开源楼32-409

电话：022-86559825

网址：www.xinkejiaye.com

XRS Cartesian Systems

Parker XRS Series “standard” Cartesian robot modules are the ideal solution for cost effective automation in life sciences, semiconductor, electronics, automated assembly, dispensing, and many other applications.

Standard XRS Systems are pre-engineered to optimize work-space, simplify selection, shorten delivery and lower costs.

Scalability

With 3 size platforms and 124 standard systems you can find a standard solution for your application.

Technology

A unique mix of linear servo motor and ballscrew drive technology provides optimized dynamic performance for today’s demanding automation applications.

Reliability

XRS Systems are built from Parker’s XR/LXR linear positioners, time tested and proven in thousands of applications worldwide.

- Pre-engineered cost-effective automation package
- Performance matched components
- Protection from environment
- Cleanroom preparation available

- Innovative strip seal design provides IP30 protection to interior components as well as enhanced overall appearance
- Inertia matched brushless servo motors provide compatibility with Parker and other industry standard drives and controls
- Pre-installed air, power and signal lines routed to moving payload for convenient hook-up and long life operation
- System cable management features “high-flex” shielded cables with quick disconnect convenience
- Precision dowel holes in carriage surface allows repeatable mounting of tooling to robot.
- Precision dowel holes in base allows repeatable mounting of entire robot module into machine
- Cleanroom preparation and other options are available for easy selection

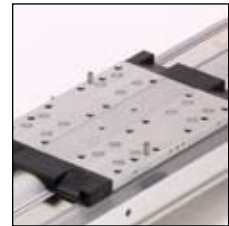

Small Platform XRS Cartesian Systems

- Smaller footprint for light loads and shorter travels
- Maximum X-Y work area: 600 mm X 300 mm
- Maximum load: 5 kg
- Recommended Parker Servo Drive:
X axis: AR-02_E
Y axis: AR-02_E
Z axis: AR-02_E



Ordering Information:

Specify the system number corresponding to the appropriate orientation and performance characteristics.

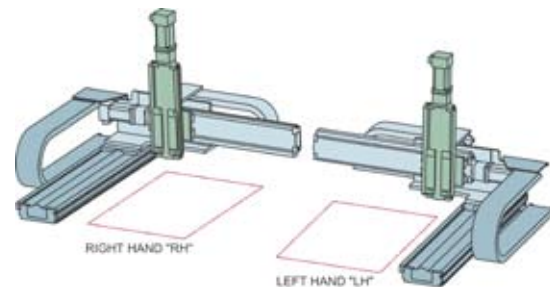

Right Hand System Number	Left Hand System Number	Max. Load (kg)	Work Envelope (mm)			Velocity (mm/sec)			Resolution (µm)			Repeatability* (µm)		
			X	Y	Z	X	Y	Z	X	Y	Z	X	Y	Z
XRS-0001	XRS-0009	5	300	300	–	600	700	–	2.5	2.5	–	16	15	–
XRS-0002	XRS-0010	5	300	300	100	600	700	140	2.5	2.5	0.5	16	15	10
XRS-0003	XRS-0011	5	600	300	–	600	700	–	2.5	2.5	–	16	15	–
XRS-0004	XRS-0012	5	600	300	100	500	700	140	2.5	2.5	0.5	16	15	10
XRS-0005	XRS-0013	5	300	300	–	1500	700	–	1	2.5	–	16	15	–
XRS-0006	XRS-0014	5	300	300	100	1500	700	140	1	2.5	0.5	16	15	10
XRS-0007	XRS-0015	5	600	300	–	2250	700	–	1	2.5	–	16	15	–
XRS-0008	XRS-0016	5	600	300	100	2250	700	140	1	2.5	0.5	16	15	10

* Repeatability established at maximum load - fully extended stroke.

Linear Motor driven actuator

Ballscrew driven actuator





Medium Platform XRS Cartesian Systems

- For mid-range loads and travels
- Maximum X-Y work area: 1000 mm X 600 mm
- Maximum load: 12 kg
- Recommended Parker Servo Drive:
 X axis: AR-04_E
 Y axis: AR-02_E
 Z axis: AR-02_E



Screw Driven Tables

Right Hand System Number	Left Hand System Number	Max. Load (kg)	Work Envelope (mm)			Velocity (mm/sec)			Resolution (µm)			Repeatability** (µm)		
			X	Y	Z	X	Y	Z	X	Y	Z	X	Y	Z
XRS-0017	XRS-0053	12	600	400	–	500	600	–	2.5	2.5	–	45	7	–
XRS-0018	XRS-0054	5	600	400	100	500	600	140	2.5	2.5	0.5	45	7	10
XRS-0019	XRS-0055	12	600	400	150	500	600	600	2.5	2.5	2.5	45	7	6
XRS-0020*	XRS-0056*	12	600	400	150	500	600	600	2.5	2.5	2.5	45	7	6
XRS-0021	XRS-0057	12	600	600	–	500	500	–	2.5	2.5	–	45	7	–
XRS-0022	XRS-0058	5	600	600	100	500	500	140	2.5	2.5	0.5	45	7	10
XRS-0023	XRS-0059	12	600	600	150	500	500	600	2.5	2.5	2.5	45	7	6
XRS-0024*	XRS-0060*	12	600	600	150	500	500	600	2.5	2.5	2.5	45	7	6
XRS-0025	XRS-0061	12	1000	600	–	350	500	–	2.5	2.5	–	45	7	–
XRS-0026	XRS-0062	5	1000	600	100	350	500	140	2.5	2.5	0.5	45	7	10
XRS-0027	XRS-0063	12	1000	600	150	350	500	600	2.5	2.5	2.5	45	7	6
XRS-0028*	XRS-0064*	12	1000	600	150	350	500	600	2.5	2.5	2.5	45	7	6
XRS-0029	XRS-0065	12	600	400	–	500	2000	–	2.5	1	–	45	5	–
XRS-0030	XRS-0066	5	600	400	100	500	2000	140	2.5	1	0.5	45	5	10
XRS-0031	XRS-0067	12	600	400	150	500	2000	600	2.5	1	2.5	45	5	6
XRS-0032*	XRS-0068*	12	600	400	150	500	2000	600	2.5	1	2.5	45	5	6
XRS-0033	XRS-0069	12	600	600	–	500	2000	–	2.5	1	–	45	5	–
XRS-0034	XRS-0070	5	600	600	100	500	2000	140	2.5	1	0.5	45	5	10
XRS-0035	XRS-0071	12	600	600	150	500	2000	600	2.5	1	2.5	45	5	6
XRS-0036*	XRS-0072*	12	600	600	150	500	2000	600	2.5	1	2.5	45	5	6
XRS-0037	XRS-0073	12	1000	600	–	350	2000	–	2.5	1	–	45	5	–
XRS-0038	XRS-0074	5	1000	600	100	350	2000	140	2.5	1	0.5	45	5	10
XRS-0039	XRS-0075	12	1000	600	150	350	2000	600	2.5	1	2.5	45	5	6
XRS-0040*	XRS-0076*	12	1000	600	150	350	2000	600	2.5	1	2.5	45	5	6
XRS-0041	XRS-0077	12	650	400	–	2000	2000	–	1	1	–	45	5	–
XRS-0042	XRS-0078	5	650	400	100	2000	2000	140	1	1	0.5	45	5	10
XRS-0043	XRS-0079	12	650	400	150	2000	2000	600	1	1	2.5	45	5	6
XRS-0044*	XRS-0080*	12	650	400	150	2000	2000	600	1	1	2.5	45	5	6
XRS-0045	XRS-0081	12	650	600	–	2000	2000	–	1	1	–	45	5	–
XRS-0046	XRS-0082	5	650	600	100	2000	2000	140	1	1	0.5	45	5	10
XRS-0047	XRS-0083	12	650	600	150	2000	2000	600	1	1	2.5	45	5	6
XRS-0048*	XRS-0084*	12	650	600	150	2000	2000	600	1	1	2.5	45	5	6
XRS-0049	XRS-0085	12	850	600	–	2000	2000	–	1	1	–	45	5	–
XRS-0050	XRS-0086	5	850	600	100	2000	2000	140	1	1	0.5	45	5	10
XRS-0051	XRS-0087	12	850	600	150	2000	2000	600	1	1	2.5	45	5	6
XRS-0052*	XRS-0088*	12	850	600	150	2000	2000	600	1	1	2.5	45	5	6

* Models indicated have the Z-axis mounted to the Y-axis "carriage to carriage", hence the Z-axis will extend & retract vertically. Note that the F dimension (see dimensions on facing page), is established when the Z-axis is at the top of the stroke.

** Repeatability is established at maximum load - fully extended stroke. Linear Motor driven actuator Ballscrew driven actuator

Large Platform XRS Cartesian Systems

- For heavier loads and travels
- Maximum X-Y work area: 1000 mm X 1000 mm
- Maximum load: 25 kg
- Recommended Parker Servo Drive:
 X axis: AR-08_E
 Y axis: AR-04_E
 Z axis: AR-02_E



Right Hand System Number	Left Hand System Number	Max. Load (kg)	Work Envelope (mm)			Velocity (mm/sec)			Resolution (µm)			Repeatability** (µm)		
			X	Y	Z	X	Y	Z	X	Y	Z	X	Y	Z
XRS-0089	XRS-0107	25	650	600	-	470	500	-	2.5	2.5	-	50	7	-
XRS-0090	XRS-0108	25	650	600	150	470	500	600	2.5	2.5	2.5	50	7	6
XRS-0091*	XRS-0109*	25	650	600	150	470	500	600	2.5	2.5	2.5	50	7	6
XRS-0092	XRS-0110	25	1000	600	-	450	500	-	2.5	2.5	-	50	7	-
XRS-0093	XRS-0111	25	1000	600	150	450	500	600	2.5	2.5	2.5	50	7	6
XRS-0094*	XRS-0112*	25	1000	600	150	450	500	600	2.5	2.5	2.5	50	7	6
XRS-0095	XRS-0113	25	1000	1000	-	450	350	-	2.5	2.5	-	50	7	-
XRS-0096	XRS-0114	25	1000	1000	150	450	350	600	2.5	2.5	2.5	50	7	6
XRS-0097*	XRS-0115*	25	1000	1000	150	450	350	600	2.5	2.5	2.5	50	7	6
XRS-0098	XRS-0116	25	650	650	-	2000	2000	-	1	1	-	50	7	-
XRS-0099	XRS-0117	25	650	650	150	2000	2000	600	1	1	2.5	50	7	6
XRS-0100*	XRS-0118*	25	650	650	150	2000	2000	600	1	1	2.5	50	7	6
XRS-0101	XRS-0119	25	1000	650	-	2000	2000	-	1	1	-	50	7	-
XRS-0102	XRS-0120	25	1000	650	150	2000	2000	600	1	1	2.5	50	7	6
XRS-0103*	XRS-0121*	25	1000	650	150	2000	2000	600	1	1	2.5	50	7	6
XRS-0104	XRS-0122	25	1000	850	-	2000	2000	-	1	1	-	50	7	-
XRS-0105	XRS-0123	25	1000	850	150	2000	2000	600	1	1	2.5	50	7	6
XRS-0106*	XRS-0124*	25	1000	850	150	2000	2000	600	1	1	2.5	50	7	6

* Models indicated have the Z-axis mounted to the Y-axis “carriage to carriage”, hence the Z-axis will extend & retract vertically. Note that the F dimension (see dimensions on facing page), is established when the Z-axis is at the top of the stroke.

** Repeatability is established at maximum load - fully extended stroke. Linear Motor driven actuator Ballscrew driven actuator



Small Platform Dimensions

Dimensions (mm)

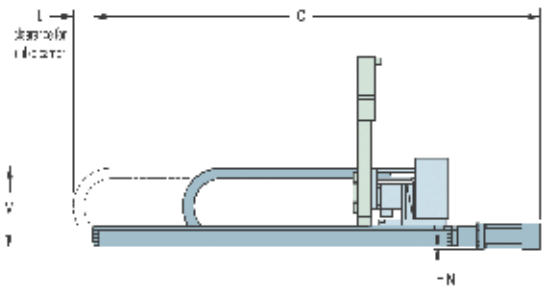
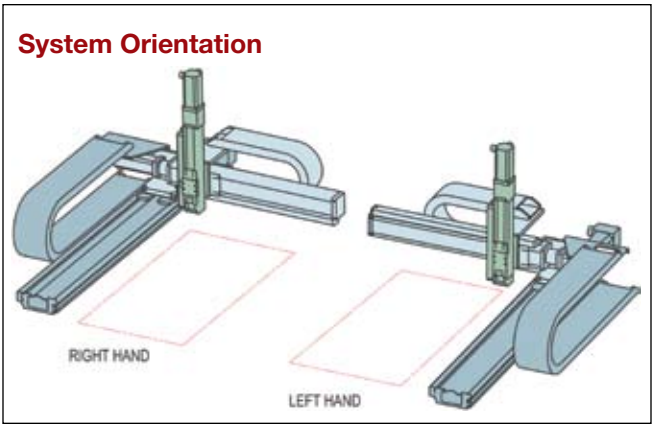
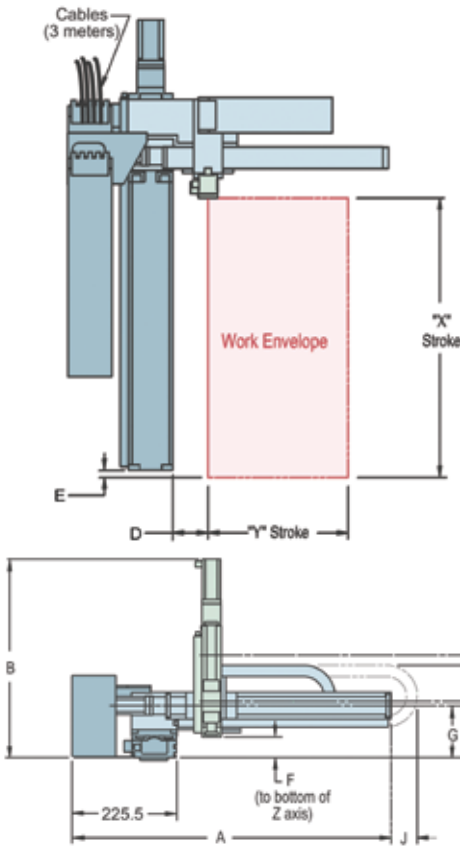

Screw Driven Tables

Right Hand System Number	Left Hand System Number	Dimensions (mm)															
		A	B	C	D	E	F	G	H	J	K	L	M	N	X	Y	Z
XRS-0001	XRS-0009	688.0	-	707.1	75.5	-27.7	-	112.0	-	35	198.7	50	198	6	300	300	-
XRS-0002	XRS-0010	688.0	463.4	707.1	75.5	15.3	46.7	112.0	120	35	198.7	50	198	6	300	300	100
XRS-0003	XRS-0011	688.0	-	1000.1	75.5	-27.7	-	112.0	-	35	198.7	50	198	6	600	300	-
XRS-0004	XRS-0012	688.0	463.4	1000.1	75.5	15.3	46.7	112.0	120	35	198.7	50	198	6	600	300	100
XRS-0005	XRS-0013	689.5	-	596.0	74.0	-71.2	-	124.7	-	35	211.5	50	211	-	300	300	-
XRS-0006	XRS-0014	689.5	476.1	596.0	74.0	-28.3	59.5	124.7	133	35	211.5	50	211	-	600	300	100
XRS-0007	XRS-0015	689.5	-	896.0	74.0	-71.2	-	124.7	-	35	211.5	50	211	-	300	300	-
XRS-0008	XRS-0016	689.5	476.1	896.0	74.0	-28.3	59.5	124.7	133	35	211.5	50	211	-	600	300	100



Medium Platform Dimensions

Dimensions (mm)

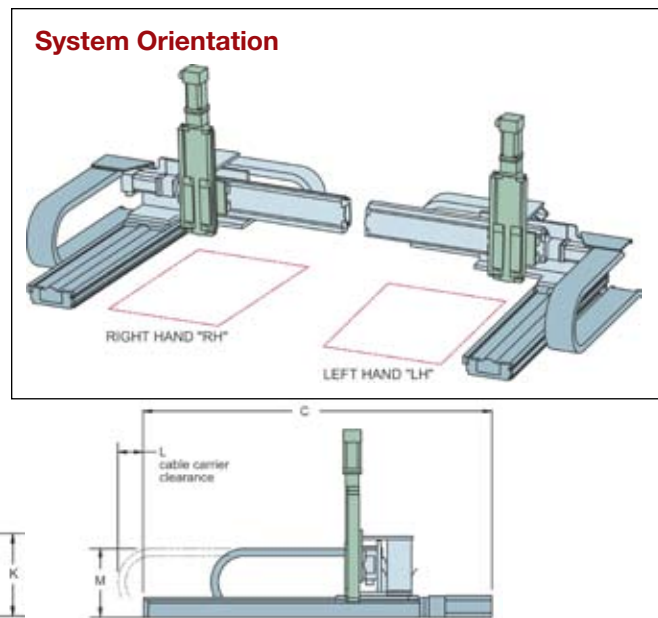
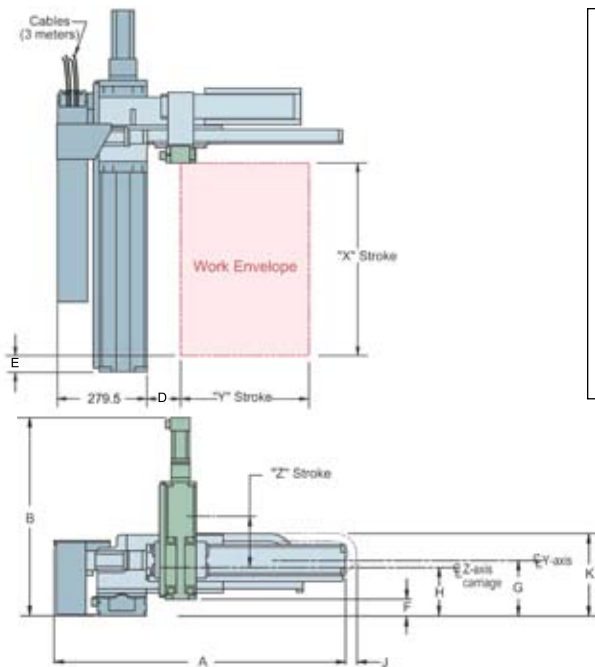

Right Hand System Number	Left Hand System Number	Dimensions (mm)														
		A	B	C	D	E	F	G	H	J	K	L	M	X	Y	Z
XRS-0017	XRS-0053	892.5	-	1127.5	105	-99.0	-	170.1	-	60	261	80	225	600	400	-
XRS-0018	XRS-0054	892.5	530.8	1127.5	105	-56.0	82.6	170.1	156	60	261	80	225	600	400	100
XRS-0019	XRS-0055	892.5	646.0	1127.5	105	-51.7	64.1	170.1	170	60	261	80	225	600	400	150
XRS-0020*	XRS-0056*	892.5	646.0	1127.5	105	-51.7	64.6*	170.1	170	60	261	80	225	600	400	150
XRS-0021	XRS-0057	1092.5	-	1127.5	105	-99.0	-	170.1	-	60	261	80	225	600	600	-
XRS-0022	XRS-0058	1092.5	530.8	1127.5	105	-56.0	82.6	170.1	156	60	261	80	225	600	600	100
XRS-0023	XRS-0059	1092.5	646.0	1127.5	105	-51.7	64.1	170.1	170	60	261	80	225	600	600	150
XRS-0024*	XRS-0060*	1092.5	646.0	1127.5	105	-51.7	64.6*	170.1	170	60	261	80	225	600	600	150
XRS-0025	XRS-0061	1092.5	-	1527.5	105	-99.0	-	170.1	-	60	261	80	225	1000	600	-
XRS-0026	XRS-0062	1092.5	530.8	1527.5	105	-56.0	82.6	170.1	156	60	261	80	225	1000	600	100
XRS-0027	XRS-0063	1092.5	646.0	1527.5	105	-51.7	64.1	170.1	170	60	261	80	225	1000	600	150
XRS-0028*	XRS-0064*	1092.5	646.0	1527.5	105	-51.7	64.6*	170.1	170	60	261	80	225	1000	600	150
XRS-0029	XRS-0065	934.5	-	1127.5	105	-86.3	-	170.1	-	30	281	80	225	600	400	-
XRS-0030	XRS-0066	934.5	530.8	1127.5	105	-43.4	82.6	170.1	156	30	281	80	225	600	400	100
XRS-0031	XRS-0067	934.5	646.0	1127.5	105	-39.0	64.1	170.1	170	30	281	80	225	600	400	150
XRS-0032*	XRS-0068*	934.5	646.0	1127.5	105	-39.0	64.6*	170.1	170	30	281	80	225	600	400	150
XRS-0033	XRS-0069	1134.5	-	1127.5	105	-86.3	-	170.1	-	30	281	80	225	600	600	-
XRS-0034	XRS-0070	1134.5	530.8	1127.5	105	-43.4	82.6	170.1	156	30	281	80	225	600	600	100
XRS-0035	XRS-0071	1134.5	646.0	1127.5	105	-39.0	64.1	170.1	170	30	281	80	225	600	600	150
XRS-0036*	XRS-0072*	1134.5	646.0	1127.5	105	-39.0	64.6*	170.1	170	30	281	80	225	600	600	150
XRS-0037	XRS-0073	1134.5	-	1527.5	105	-86.3	-	170.1	-	30	281	80	225	1000	600	-
XRS-0038	XRS-0074	1134.5	530.8	1527.5	105	-43.4	82.6	170.1	156	30	281	80	225	1000	600	100
XRS-0039	XRS-0075	1134.5	646.0	1527.5	105	-39.0	64.1	170.1	170	30	281	80	225	1000	600	150
XRS-0040*	XRS-0076*	1134.5	646.0	1527.5	105	-39.0	64.6*	170.1	170	30	281	80	225	1000	600	150
XRS-0041	XRS-0077	934.5	-	1117.6	105	-158.3	-	170.1	-	30	281	35	225	650	400	-
XRS-0042	XRS-0078	934.5	530.8	1117.6	105	-115.3	82.6	170.1	156	30	281	35	225	650	400	100
XRS-0043	XRS-0079	934.5	646.0	1117.6	105	-111.0	64.1	170.1	170	30	281	35	225	650	400	150
XRS-0044*	XRS-0080*	934.5	646.0	1117.6	105	-111.0	64.6*	170.1	170	30	281	35	225	650	400	150
XRS-0045	XRS-0081	1134.5	-	1117.6	105	-158.3	-	170.1	-	30	281	35	225	650	600	-
XRS-0046	XRS-0082	1134.5	530.8	1117.6	105	-115.3	82.6	170.1	156	30	281	35	225	650	600	100
XRS-0047	XRS-0083	1134.5	646.0	1117.6	105	-111.0	64.1	170.1	170	30	281	35	225	650	600	150
XRS-0048*	XRS-0084*	1134.5	646.0	1117.6	105	-111.0	64.6*	170.1	170	30	281	35	225	650	600	150
XRS-0049	XRS-0085	1134.5	-	1317.6	105	-158.3	-	170.1	-	30	281	35	225	850	600	-
XRS-0050	XRS-0086	1134.5	530.8	1317.6	105	-115.3	82.6	170.1	156	30	281	35	225	850	600	100
XRS-0051	XRS-0087	1134.5	646.0	1317.6	105	-111.0	64.1	170.1	170	30	281	35	225	850	600	150
XRS-0052*	XRS-0088*	1134.5	646.0	1317.6	105	-111.0	64.6*	170.1	170	30	281	35	225	850	600	150

* Models indicated have the Z-axis mounted to the Y-axis "carriage to carriage", hence the Z-axis will extend & retract vertically. Note that the F dimension is established when the Z-axis is at the top of the stroke.



Large Platform Dimensions

Dimensions (mm)

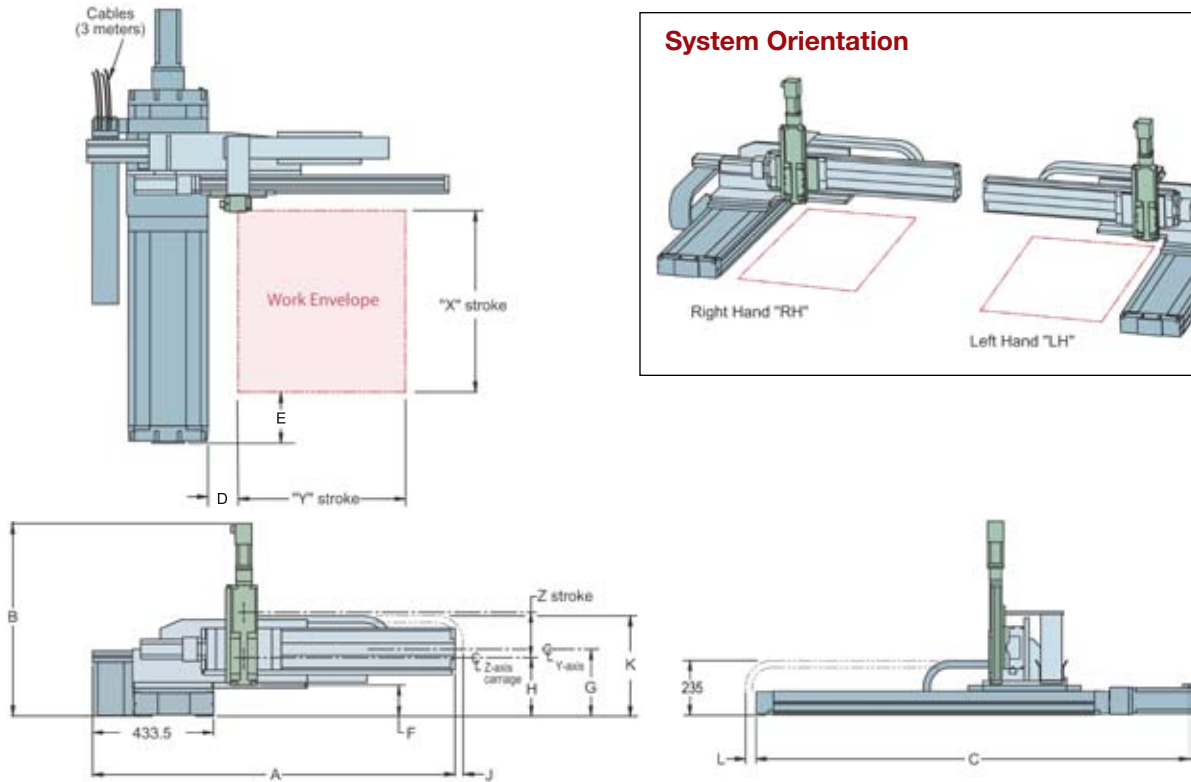

Screw Driven Tables

Right Hand System Number	Left Hand System Number	Dimensions (mm)													
		A	B	C	D	E	F	G	H	J	K	L	X	Y	Z
XRS-0089	XRS-0107	1299.0	-	1553.5	108.5	-222.3	-	239.9	-	80	389.9	0	650	600	-
XRS-0090	XRS-0108	1299.0	690.3	1553.5	108.5	-175.0	108.9	239.9	214.9	80	389.9	0	650	600	150
XRS-0091*	XRS-0109*	1299.0	715.3	1553.5	108.5	-175.0	133.9*	239.9	239.9	80	389.9	0	650	600	150
XRS-0092	XRS-0110	1299.0	-	1553.5	108.5	-222.3	-	239.9	-	80	389.9	0	1000	600	-
XRS-0093	XRS-0111	1299.0	690.3	1553.5	108.5	-175.0	108.9	239.9	214.9	80	389.9	0	1000	600	150
XRS-0094*	XRS-0112*	1299.0	715.3	1553.5	108.5	-175.0	133.9*	239.9	239.9	80	389.9	0	1000	600	150
XRS-0095	XRS-0113	1699.0	-	1903.5	108.5	-222.3	-	239.9	-	80	389.9	0	1000	1000	-
XRS-0096	XRS-0114	1699.0	690.3	1903.5	108.5	-175.0	108.9	239.9	214.9	80	389.9	0	1000	1000	150
XRS-0097*	XRS-0115*	1699.0	715.3	1903.5	108.5	-175.0	133.9*	239.9	239.9	80	389.9	0	1000	1000	150
XRS-0098	XRS-0116	1392.5	-	1264.0	100.0	-222.3	-	239.9	-	80	389.9	0	650	650	-
XRS-0099	XRS-0117	1392.5	690.3	1264.0	100.0	-175.0	108.9	239.9	214.9	80	389.9	0	650	650	150
XRS-0100*	XRS-0118*	1392.5	715.3	1264.0	100.0	-175.0	133.9*	239.9	239.9	80	389.9	0	650	650	150
XRS-0101	XRS-0119	1392.5	-	1614.0	100.0	-222.3	-	239.9	-	80	389.9	0	1000	650	-
XRS-0102	XRS-0120	1392.5	690.3	1614.0	100.0	-175.0	108.9	239.9	214.9	80	389.9	0	1000	650	150
XRS-0103*	XRS-0121*	1392.5	715.3	1614.0	100.0	-175.0	133.9*	239.9	239.9	80	389.9	0	1000	650	150
XRS-0104	XRS-0122	1592.5	-	1614.0	100.0	-222.3	-	239.9	-	80	389.9	0	1000	850	-
XRS-0105	XRS-0123	1592.5	690.3	1614.0	100.0	-175.0	108.9	239.9	214.9	80	389.9	0	1000	850	150
XRS-0106*	XRS-0124*	1592.5	715.3	1614.0	100.0	-175.0	133.9*	239.9	239.9	80	389.9	0	1000	850	150

* Models indicated have the Z-axis mounted to the Y-axis "carriage to carriage", hence the Z-axis will extend & retract vertically. Note that the F dimension is established when the Z-axis is at the top of the stroke.