



## 300AT Series Open Frame Tables

### Features

- Large clear aperture
- Travel ranges up to 24 in x 24 in
- Non-recirculating linear ball bearing for smoothest linear translation
- Precision ground leadscrew drive for accurate, repeatable positioning ( $\pm 0.00012$  in)
- Single and dual axis models

### Quality Design and Construction

The 300AT Series Linear Tables, like the 100BT Series Tables incorporate a non-recirculating linear ball bearing system to produce extremely smooth linear translation with excellent straightline and flatness accuracy. They also offer a precision ground leadscrew drive mechanism which is preloaded to provide highly precise positional accuracy and repeatability.

The 300AT, however, has the drive mechanism located on the side of the unit to allow for a clear opening through the center of the table(s). This center opening (aperture) enables these tables to be utilized in a variety of applications where light or objects can pass through the table. These include component insertion and assembly, back-lit inspection, and scanning applications.

Table elements are constructed of high quality aluminum alloy and are protected with black anodized surface finish. The top and bottom mounting surfaces are precision machined to assure flatness, and fixturing holes are fitted with locking steel threaded inserts. These units are offered in English or Metric versions, and in two grades: precision grade and standard grade which permit cost savings to be realized in less demanding applications.

### Options:

#### Motor Couplings

A wide range of coupling styles and bores are available to match motor requirements. Bellows-style couplings are required for all precision grade tables and have the lowest radial windup, while the aluminum and stainless steel helix couplers offer good windup characteristics and high durability at a lower cost.

#### Motor Mounts

The motor mount is designed for an industry standard NEMA 23 motor flange with shaft lengths between 0.65 and 0.85 inches.



Screw Driven  
Tables

### Limit and Home Switches

All styles can be equipped with either mechanical reed switch or optical sensor type limit and home switch assemblies. The limit switches provide a signal when the table is approaching its end of travel which is used to command the motor to stop. The Home sensor provides a fixed reference point to which the table can always return.

### Linear Encoders

This option is used to give direct positional feedback of the carriage. English resolution of 0.0001 inch and Metric resolution of 0.001 mm are available. These units mount to the inside of the table for improved performance. This causes the aperture to be reduced by approximately 1 inch.

**Note:** Refer to [www.parkermotion.com](http://www.parkermotion.com) or contact a Parker applications engineer for additional detailed information pertaining to 400ST options or accessories.



## 天津昕科佳业科技有限公司

地址：天津市红桥区咸阳北路开源楼32-409

电话：022-86559825

网址：[www.xinkejiaye.com](http://www.xinkejiaye.com)

**Common Characteristics**

	Units	Precision	Standard
<b>Performance</b>			
Positional Repeatability (bidirectional)	x 0.001 in (µm)	±0.12 (±3.0)	±0.47 (±12)
X-Y Squareness*	Arc Seconds	30	60
Life @ rated Load Cap.	x 1 million in (km)	10 (254)	10 (254)
Duty Cycle	%	75	50
Acceleration (Max.)	in/sec (m/sec)	48 (1.2)	24 (0.6)
<b>Maximum Screw Speed</b>			
Less than 16 inch travels		25	15
16 inch & higher travels		15	15
<b>Motor Sizing</b>			
Leadscrew Diameter	in (mm)	0.5 (12.7)	0.5 (12.7)
Drive Screw Efficiency	%	30	30
Breakaway Torque (Max.)	oz-in (N-m)	16.5 (0.117)	16.5 (0.117)
Running Torque (Max.)	oz-in (N-m)	15 (0.106)	15 (0.106)
<b>Coefficient of Friction - Linear Bearing</b>		0.003	0.003

\*Two Axis (X-Y) Units

**Travel Dependent Characteristics**

Model Number	Travel		Load Capacity*			Positional Accuracy**		Straightness & Flatness Accuracy**		Input Inertia***		Carriage Weight		Table Weight	
	X-Axis in	Y-Axis in	Normal lbs	Inverted lbs	Axial lbs	x 0.001 in	x 0.001 in	x 0.001 in	x 0.001 in	10 <sup>-3</sup> oz-in-sec <sup>2</sup>	10 <sup>-5</sup> kg-m <sup>2</sup>	lbs	kgf	lbs	kgf
<b>Precision Grade Specifications</b>															
310062AT	6.0 (150)	6.0 (150)	160 (72)	80 (36)	55 (24.9)	0.9 (24)	1.2 (31)	1.2 (31)	1.2 (31)	1.20 (0.85)	4.9 (2.2)	25 (11.3)			
315081AT	8.0 (200)	—	245 (111)	122 (56)	55 (24.9)	1.3 (32)	1.6 (41)	1.6 (41)	1.6 (41)	1.75 (1.23)	8.3 (3.8)	36 (16.3)			
315082AT	8.0 (200)	8.0 (200)	210 (95)	105 (47)	55 (24.9)	1.3 (32)	1.6 (41)	1.6 (41)	1.6 (41)	2.56 (1.81)	44.3 (20.1)	72 (32.7)			
315101AT	10.0 (250)	—	245 (111)	122 (56)	55 (24.9)	1.6 (40)	2.0 (51)	2.0 (51)	2.0 (51)	1.75 (1.23)	8.3 (3.8)	36 (16.3)			
315102AT	10.0 (250)	10.0 (250)	210 (95)	105 (47)	55 (24.9)	1.6 (40)	2.0 (51)	2.0 (51)	2.0 (51)	2.56 (1.81)	44.3 (20.1)	72 (32.7)			
318121AT	12.0 (300)	—	300 (136)	150 (68)	55 (24.9)	1.9 (48)	2.4 (61)	2.4 (61)	2.4 (61)	2.03 (1.43)	10.2 (4.6)	43 (19.5)			
318122AT	12.0 (300)	12.0 (300)	260 (118)	130 (59)	55 (24.9)	1.9 (48)	2.4 (61)	2.4 (61)	2.4 (61)	3.02 (2.13)	53.2 (24.1)	86 (39)			
324161AT	16.0 (400)	—	370 (168)	185 (84)	55 (24.9)	2.5 (66)	3.2 (81)	3.2 (81)	3.2 (81)	2.60 (1.84)	14.2 (6.4)	58 (26.3)			
324162AT	16.0 (400)	16.0 (400)	310 (141)	155 (70)	55 (24.9)	2.5 (66)	3.2 (81)	3.2 (81)	3.2 (81)	3.94 (2.78)	72.2 (32.7)	116 (52.6)			
330241AT	24.0 (600)	—	440 (200)	220 (100)	55 (24.9)	3.9 (98)	4.8 (122)	4.8 (122)	4.8 (122)	3.43 (2.42)	27.7 (12.6)	72 (32.7)			
330242AT	24.0 (600)	24.0 (600)	380 (172)	119 (86)	55 (24.9)	3.9 (98)	4.8 (122)	4.8 (122)	4.8 (122)	5.30 (3.47)	99.7 (45.2)	145 (65.8)			
<b>Standard Grade Specifications</b>															
310062AT	6.0 (150)	6.0 (150)	160 (72)	80 (36)	55 (24.9)	1.2 (30)	3.0 (76)	3.0 (76)	3.0 (76)	1.2 (0.85)	4.9 (2.2)	25 (11.3)			
315081AT	8.0 (200)	—	245 (111)	122 (56)	55 (24.9)	1.6 (40)	4.0 (102)	4.0 (102)	4.0 (102)	1.75 (1.23)	8.3 (3.8)	36 (16.3)			
315082AT	8.0 (200)	8.0 (200)	210 (95)	105 (47)	55 (24.9)	1.6 (40)	4.0 (102)	4.0 (102)	4.0 (102)	2.56 (1.81)	44.3 (20.1)	72 (32.7)			
315101AT	10.0 (250)	—	245 (111)	122 (56)	55 (24.9)	2.0 (50)	5.0 (127)	5.0 (127)	5.0 (127)	1.75 (1.23)	8.3 (3.8)	36 (16.3)			
315102AT	10.0 (250)	10.0 (250)	210 (95)	105 (47)	55 (24.9)	2.0 (50)	5.0 (127)	5.0 (127)	5.0 (127)	2.56 (1.81)	44.3 (20.1)	72 (32.7)			
318121AT	12.0 (300)	—	300 (136)	150 (68)	55 (24.9)	2.4 (61)	6.0 (152)	6.0 (152)	6.0 (152)	2.03 (1.43)	10.2 (4.6)	43 (19.5)			
318122AT	12.0 (300)	12.0 (300)	260 (118)	130 (59)	55 (24.9)	2.4 (61)	6.0 (152)	6.0 (152)	6.0 (152)	3.02 (2.13)	53.2 (24.1)	86 (39)			
324161AT	16.0 (400)	—	370 (168)	185 (84)	55 (24.9)	3.2 (81)	8.0 (203)	8.0 (203)	8.0 (203)	2.6 (1.84)	14.2 (6.4)	58 (26.3)			
324162AT	16.0 (400)	16.0 (400)	310 (141)	155 (70)	55 (24.9)	3.2 (81)	8.0 (203)	8.0 (203)	8.0 (203)	3.94 (2.78)	72.2 (32.7)	116 (52.6)			
330241AT	24.0 (600)	—	440 (200)	220 (100)	55 (24.9)	4.8 (122)	12.0 (305)	12.0 (305)	12.0 (305)	3.43 (2.42)	27.7 (12.6)	72 (32.7)			
330242AT	24.0 (600)	24.0 (600)	380 (172)	119 (86)	55 (24.9)	4.8 (122)	12.0 (305)	12.0 (305)	12.0 (305)	5.3 (3.47)	99.7 (45.2)	145 (65.8)			

\*Refer to www.parkermotion.com for moment load graph.

\*\*Measured over centerline of drive screw.

\*\*\*Based on 0.2 in lead drive screw (D3 option).

\*\*\*\*2 axis units: Inertia and Carriage weight are shown for Base axis sizing. For sizing top axis use single axis specifications.

Refer to [www.parkermotion.com](http://www.parkermotion.com) for additional technical information.





300AT Series Dimensions

Dimensions – in (mm)

310000AT

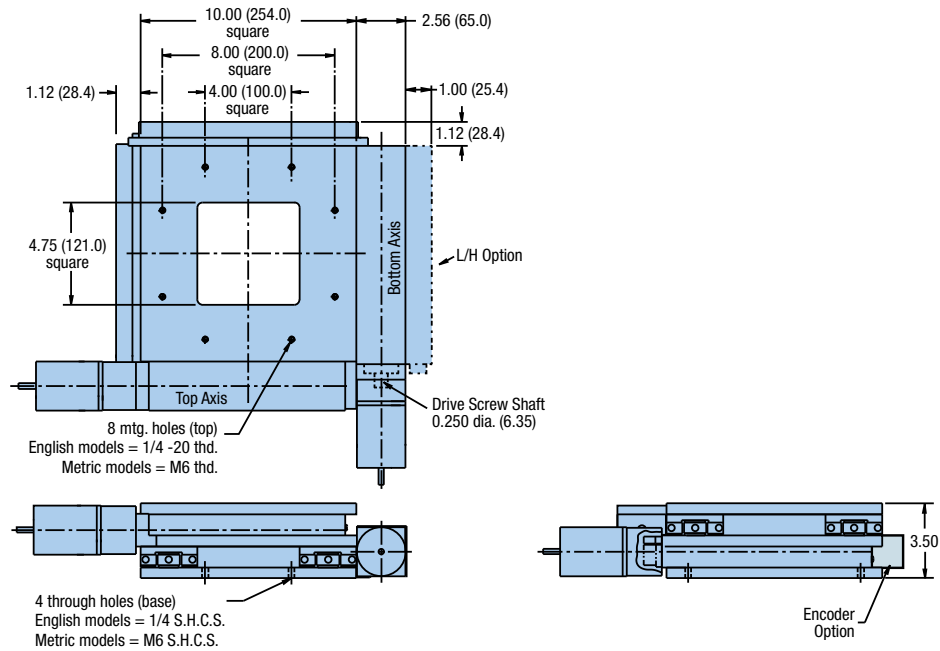

315000AT/318000AT/324000/330000AT

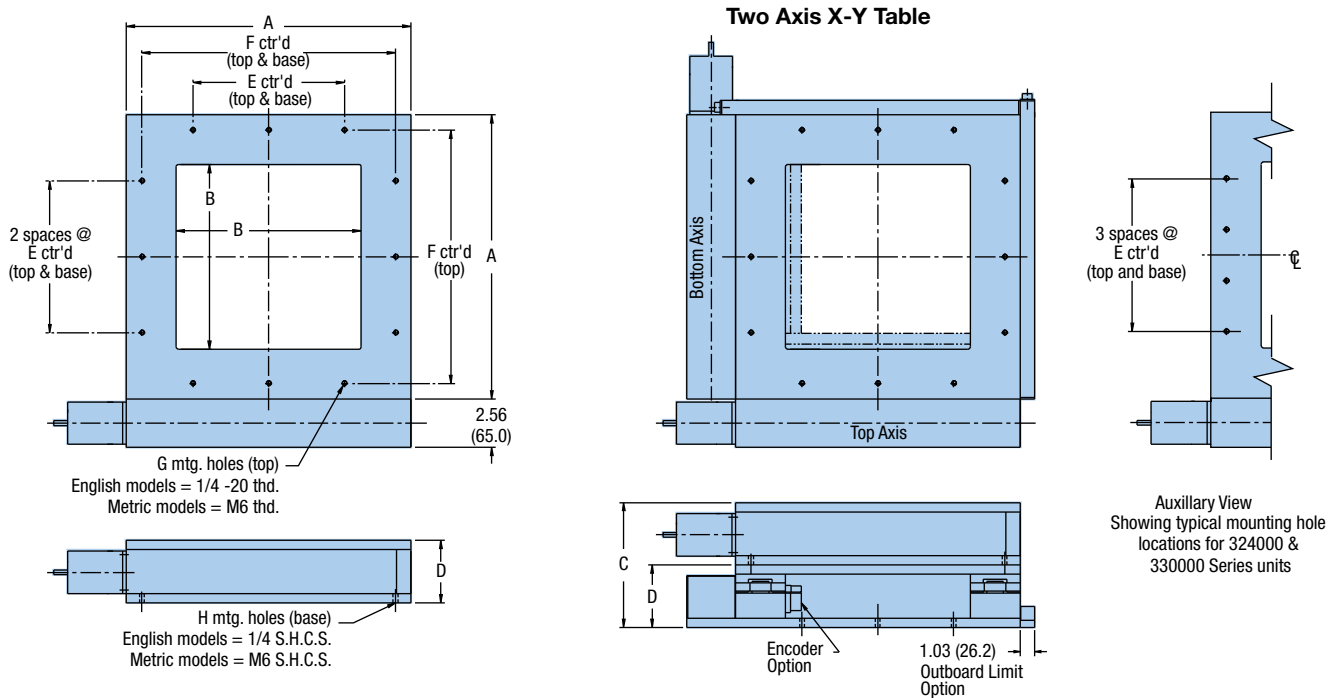

Model Number	Width	Opening	X-Y Axis	X Axis	E	F	Mounting	
	A	B	C	D			G	H
<b>English</b>								
315000AT-E	15 in	9.75 in	6.5 in	3.25 in	8 in	13.38 in	12	6
318000AT-E	18 in	12.75 in	6.5 in	3.25 in	10 in	16.38 in	12	6
324000AT-E	24 in	18.75 in	6.5 in	3.25 in	15 in	22.38 in	16	8
330000AT-E	30 in	24.75 in	6.5 in	3.25 in	22.5 in	28.38 in	16	8
<b>Metric</b>								
315000AT-M	381 mm	248 mm	165.1 mm	82.5 mm	200 mm	325 mm	12	6
318000AT-M	457 mm	324 mm	165.1 mm	82.5 mm	250 mm	400 mm	12	6



Screw Driven Tables

Fill in an order code from each of the numbered fields to create a complete model order code.

① ② ③ ④ ⑤ ⑥ ⑦ ⑧ ⑨ ⑩ ⑪

**Order Example:** 3 1510 2 AT E S D2 L2 C2 M1 E2

① **Series**

3

② **Width/Travel—English Models in; Metric Models (mm)**

	Width	Travel	
1006	10 in (250 mm)	6 in (150 mm)	Two axis only
1508	15 in (375 mm)	8 in (200 mm)	
1510	15 in	10 in	English only
1812	18 in (450 mm)	12 in (300 mm)	
2416	24 in	16 in	English only
3024	33 in	24 in	English only

③ **Number of Axes**

- 1 One axis
- 2 Two axis

④ **Table Style**

AT

⑤ **Mounting**

- E English
- M Metric

⑥ **Grade**

- S Standard
- P Precision

⑦ **Drive Screw**

- D1 0.02 in lead (50 pitch)
- D2 0.10 in lead (10 pitch)
- D3 0.20 in lead (5 pitch)
- D4 1.0 mm lead
- D5 2.0 mm lead
- D6 5.0 mm lead

⑧ **Limit/Home**

- L1 No limit/home switches
- L2 Magnetic limit/home switches
- L3 Optical limit/home switches (outboard)
- L4 Magnetic limit/home switches (outboard)

⑨ **Motor Coupling**

- C1 No coupling
- C2 0.25 in bore, helix, aluminum
- C3 0.25 in bore, helix, stainless steel
- C4 0.25 in bore, bellows, required for precision grade
- C6 0.375 in bore, helix, stainless steel
- C7 0.375 in bore, bellows, required for precision grade

⑩ **Motor Mount**

- M1 23 frame size

⑪ **Encoder**

- E1 No encoder
- E2 Linear encoder, English, 0.0001 in resolution
- E3 Linear encoder, Metric, 1.0 µm resolution



## Solutions for X-Y Inspection

Parker Hannifin Corporation's Daedal Division introduces new mechanical solutions for special X-Y inspection stations. These precision devices provide alternatives for high speed, very low profile applications.

Daedal will modify the standard base structure to fit various work stations. For application assistance in configuring the X-Y inspect on positioners, contact your local Automation Technology Center or Daedal's Application Engineering Department.

The Daedal X-Y Precision Inspection Positioners incorporate low profile linear guide rail bearings, precision ground ballscrews and limit home optical switch assemblies. The inspection positioners provide accurate motion in a configuration which is ideal for applications which are restricted due to space limitations (less than 2 inches in height from case to carriage top of X-Y). These positioners have been designed to fit various microscope bases such as Nikon, Zeiss, and Lecks Ergoplan and can be incorporated into other application including water inspection and handling mask and die inspection, cell counting and analysis coordinate measurement and machine vision less stands. These applications an many others subject a positioner to endure high duty cycles. The new Daedal design allows increased throughput and ensures a service free life.

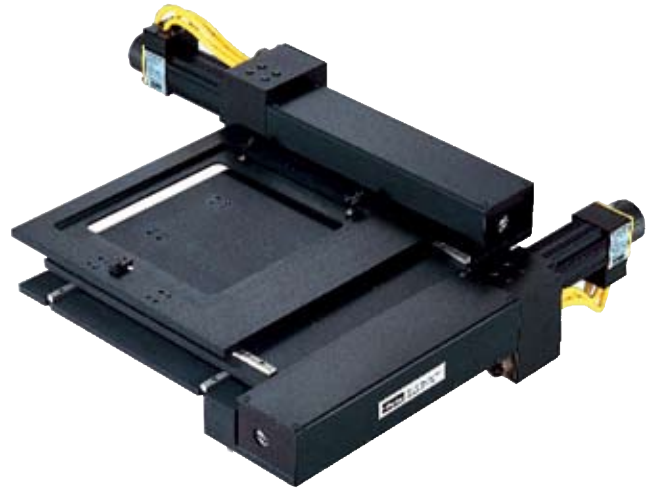

Screw Driven  
Tables

**Specifications**

The X-Y Inspection Positioner incorporates two Compumotor SM162B servo motors (NEMA 16 frame size) with 1250 line encoders. A resolution of 1 micron can be achieved (post quadrature) when mated with the 5 mm lead precision ground ballscrews found in the X-Y inspection stage. Industry standard NEMA 23 motor blocks are available for stepper applications.

Compumotor supplies various indexers and drives (servo or stepper) that provide a complete Parker solution for many applications.

	Axis 1	Axis 2
<b>Load</b>	—	1.5 Kg
<b>Drive Screw</b>	5 mm	5 mm
<b>Grade</b>	Precision Ground Ballscrew	Precision Ground Ballscrew
<b>Plane of Operation</b>	Horizontal	Horizontal
<b>Positional Accuracy</b>	10 Micron	10 Micron
<b>Straight Line Accuracy</b>	2 Micron	2 Micron
<b>Flatness</b>	15 Micron	15 Micron
<b>Bidirectional Repeatability</b>	±2 Micron	±2 Micron
<b>Maximum Velocity Mechanical Limit</b>	254 mm/sec	254 mm/sec
<b>Duty Cycle</b>	100%	100%
<b>Weight</b>	9.3 Kg	9.3 Kg

**Dimensions**

