

BE Series Servo Motors

High-Torque Design, Low-Cost Package



Parker's BE Series brushless servo motors produce high continuous stall torque in a cost-saving and performance-enhancing package.

The BE Series is designed specifically as a very cost-effective alternative to comparably sized servos. The BE Series also provides exceptional torque with the design's increased number of magnetic poles. Comparably sized servos have four magnetic poles on the rotor, while BE Series motors have eight.



Unlike traditional servo motors, the BE Series does not have a separate metal housing. Instead, the motor stator laminations are not only used for performance, but provide both structural integrity and the motor shape. This design reduces both material costs and the time required to assemble the motor.

In addition to the manufacturing advantages, the exposed laminations reduce thermal resistance. This allows the heat generated by the motor to escape to the ambient surroundings more efficiently, thus improving time in the peak region and duty cycle.

Parker's wide range of Bayside® planetary gearheads are perfectly matched to the BE Series motor. Easy selection can be made using Parker's MotionSizer.

Features

- **NEMA 16, 23, and 34 sizes**
- **From 1.4 to 46.8 in-lb (5.24 Nm) continuous torque**
- **Brushless construction**
- **Eight-pole open-lamination design provides increased torque and lower cost**
- **High torque density packaging**
- **Bridged stator design – quiet operation**
- **High performance neodymium magnets**
- **Thermoswitch protection on NEMA 23 and 34 sizes**
- **2000 line encoder standard (8000 ppr post-quad)**
- **Resolver feedback option**
- **Several connector design choices**
- **Holding brake option available on size 34, custom order on size 23**
- **Custom modifications available**
- **Industry-leading 10-day delivery**
- **Two year warranty**
- **STP solid models and CAD (dxf) drawings available (free download at www.parkermotion.com)**
- **CE and ROHS Compliant**

Parker核心代理商



北京润诚时代科技有限公司
自动化事业部

地址：北京市朝阳区汤立路218号C座968室

邮编：100012

电话：010-84450370

传真：010-84450371

网址：www.runcheng.net

ENGINEERING YOUR SUCCESS.

BE Series Servo Motors

NEMA Size 16 Performance (Data at 120 VAC)

Model Size	Symbol	Units	BE161C	BE161D	BE161F	BE162C	BE162D	BE162F
Stall Torque Continuous ^{1,2,3}	T_{CS}	Nm	0.15	0.16	0.15	0.26	0.28	0.27
		in-lb	1.3	1.4	1.3	2.3	2.4	2.4
Stall Current Continuous ^{1,2,3}	$I_{CS(rms)}$	A_{rms}	2.0	3.2	4.9	2.1	3.2	4.8
		Nm	0.45	0.47	0.46	0.78	0.83	0.82
Peak Torque ⁸	T_{Pk}	in-lb	4.0	4.2	4.1	6.9	7.4	7.2
		A_{rms}	6.1	9.7	14.7	6.4	9.5	14.5
Peak Current ⁸	$I_{Pk(rms)}$	A_{rms}	6.1	9.7	14.7	6.4	9.5	14.5
Rated Speed ^{1,2,3,4}	S_r	rpm	4965	4965	4965	4965	4965	4965
		Nm	0.12	0.13	0.12	0.21	0.22	0.22
Rated Torque ^{1,2,3}	T_r	in-lb	1.1	1.1	1.1	1.9	2.0	1.9
		kW	0.06	0.07	0.06	0.11	0.12	0.11
Shaft Power @ Rated Speed ^{1,2,3}	P_{out}	kW	0.06	0.07	0.06	0.11	0.12	0.11
Current @ Rated Speed ^{1,2,3}	I_r	Arms	1.9	3.0	4.6	1.9	2.8	4.3
Voltage Constant ^{4,7}	K_e	V_{rms}/k_{rpm}	4.51	2.98	1.90	7.37	5.34	3.43
Torque Constant ^{4,7}	$K_{t(sine)}$	Nm/A_{rms}	0.07	0.05	0.03	0.12	0.09	0.06
Resistance ^{4,7}	R	ohm	4.31	1.71	0.74	4.38	2.03	0.87
Inductance ^{5,7}	L	mH	12.10	5.30	2.16	16.14	8.46	3.50
Max DC bus Voltage ⁶	V_{mbus}	VDC _{max}	340	170	170	340	170	170
Max AC Voltage ⁶	V_s	VAC	240	120	120	240	120	120
Rotor Inertia ⁶	J	kg-m2	1.28 ⁻⁶	1.28 ⁻⁶	1.28 ⁻⁶	2.01 ⁻⁶	2.01 ⁻⁶	2.01 ⁻⁶
		in-lb-sec ²	1.14 ⁻⁵	1.14 ⁻⁵	1.14 ⁻⁵	1.78 ⁻⁵	1.78 ⁻⁵	1.78 ⁻⁵
Motor Weight ⁶		kg	0.25	0.25	0.25	0.35	0.35	0.35
		lb	0.56	0.56	0.56	0.76	0.76	0.76

Model Size	Symbol	Units	BE163C	BE163D	BE163F	BE164C	BE164D	BE164F	BE164Z
Stall Torque Continuous ^{1,2,3}	T_{CS}	Nm	0.33	0.34	0.33	0.40	0.42	0.42	0.38
		in-lb	2.9	3.0	2.9	3.6	3.8	3.7	3.4
Stall Current Continuous ^{1,2,3}	$I_{CS(rms)}$	A_{rms}	2.0	2.9	4.4	2.2	2.7	4.2	1.1
		Nm	1.00	1.02	1.00	1.22	1.29	1.28	1.15
Peak Torque	T_{Pk}	in-lb	8.8	9.0	8.9	10.8	11.4	11.3	10.2
		A_{rms}	6.1	8.6	13.3	6.5	8.1	12.7	3.4
Peak Current	$I_{Pk(rms)}$	A_{rms}	6.1	8.6	13.3	6.5	8.1	12.7	3.4
Rated Speed ^{1,2,3}	S_r	rpm	4965	4965	4965	4965	4965	4965	3310
		Nm	0.25	0.26	0.26	0.30	0.32	0.32	0.33
Rated Torque ^{1,2,3}	T_r	in-lb	2.2	2.3	2.3	2.7	2.9	2.8	2.9
		kW	0.13	0.14	0.13	0.16	0.17	0.17	0.12
Shaft Power @ Rated Speed ^{1,2,3}	P_{out}	kW	0.13	0.14	0.13	0.16	0.17	0.17	0.12
Current @ Rated Speed ^{1,2,3}	I_r	Arms	1.7	2.4	3.8	1.8	2.2	3.5	1.0
Voltage Constant ^{4,7}	K_e	V_{rms}/k_{rpm}	9.91	7.24	4.57	11.44	9.66	6.10	20.58
Torque Constant ^{4,7}	$K_{t(sine)}$	Nm/A_{rms}	0.16	0.12	0.08	0.19	0.16	0.10	0.34
Resistance ^{4,7}	R	ohm	4.77	2.42	1.0	4.65	2.98	1.2	16.78
Inductance ^{5,7}	L	mH	19.45	10.39	4.14	19.43	13.86	5.53	62.95
Max DC bus Voltage ⁶	V_{mbus}	VDC _{max}	340	170	170	340	170	170	340
Max AC Voltage ⁶	V_s	VAC	240	120	120	240	120	120	240
Rotor Inertia ⁶	J	kg-m2	2.75 ⁻⁶	2.75 ⁻⁶	2.75 ⁻⁶	3.48 ⁻⁶	3.48 ⁻⁶	3.48 ⁻⁶	3.48 ⁻⁶
		in-lb-sec ²	2.43 ⁻⁵	2.43 ⁻⁵	2.43 ⁻⁵	3.08 ⁻⁵	3.08 ⁻⁵	3.08 ⁻⁵	3.08 ⁻⁵
Motor Weight ⁶		kg	0.48	0.48	0.48	0.57	0.57	0.57	0.57
		lb	1.05	1.05	1.05	1.26	1.26	1.26	1.26

Note: These specifications are based on theoretical motor performance and are not specific to any amplifier.

¹ @ 25°C ambient, 125°C winding temperature, motor connected to a 10" x 10" x 1/4" aluminum mounting plate;

@ 40°C ambient derate phase currents and torques by 6%.

² Maximum winding temperature is 155 °C. Thermal protection device threshold may be at a lower temperature.

³ These ratings are valid for Parker drives. Other drives may not achieve the same ratings.

⁴ Maximum speed is 5000 rpm.

⁵ Measured line-to-line, ±10%. ±30%, line-to-line inductance bridge measurement @1Khz.

⁶ Reference only.

⁷ Total motor torque per peak of the sinusoidal amps measured in any phase, ±10%.

⁸ Initial winding temperature must be 60°C or less before peak current is applied.

⁹ No thermal switch within BE16. Use servo drive thermal model for overtemp protection or lower peak current.

NEMA Size 16 Speed-Torque Performance

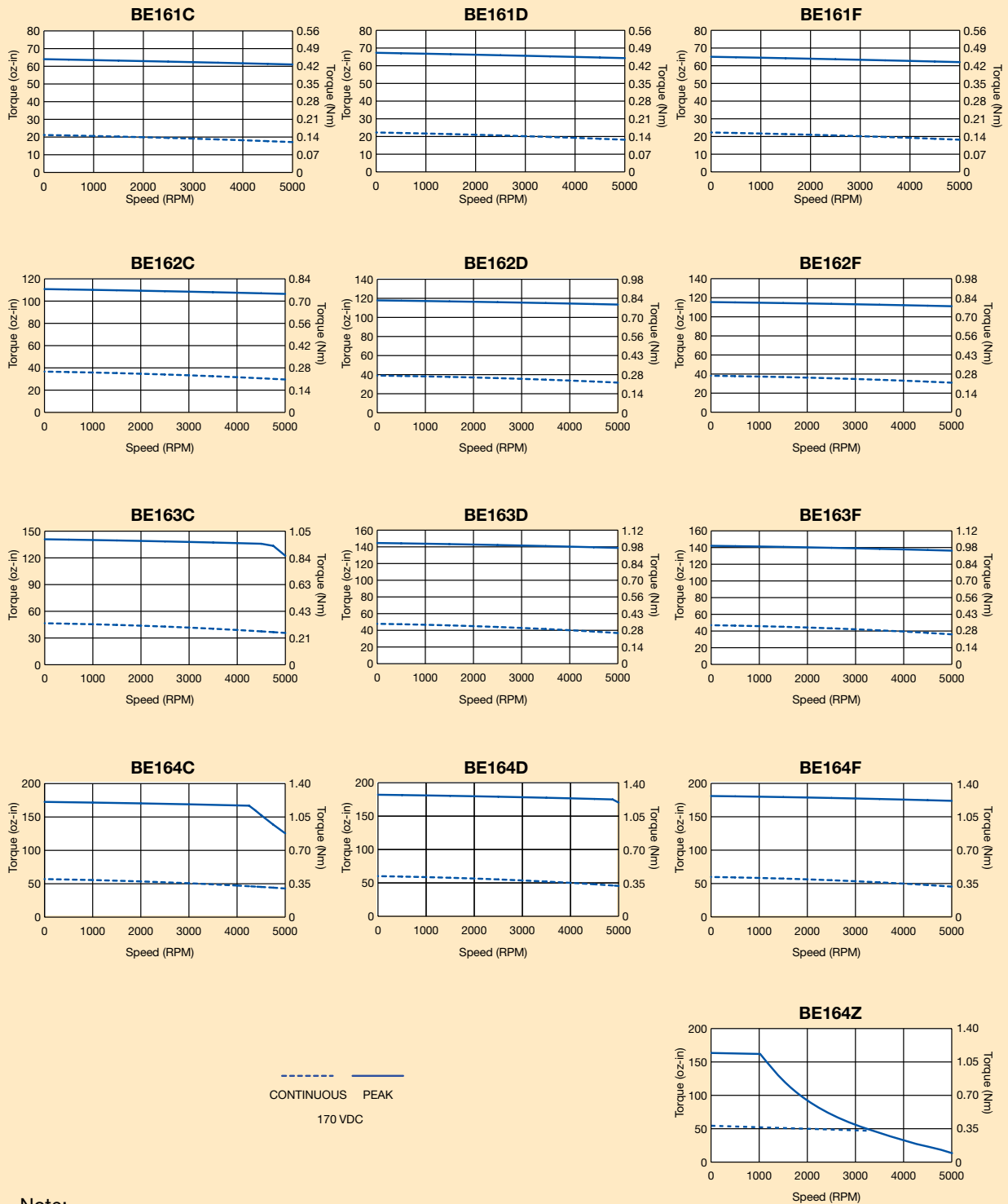

Note:

120 VAC input to drive is 170 VDC bus

For performance with different voltages and windings, see Parker Motion Sizer or Parker System Solution Finder software, free download available at www.parkermotion.com

BE Series Servo Motors

NEMA Size 23 Performance (Data at 240 VAC)

Model Size	Symbol	Units	BE230D	BE230F	BE230G	BE231D	BE231F	BE231G
Stall Torque Continuous ^{1,2,3}	T_{CS}	Nm	0.37	0.37	0.38	0.67	0.66	0.66
		in-lb	3.3	3.3	3.3	5.9	5.8	5.9
Stall Current Continuous ^{1,2,3}	$I_{CS(rms)}$	A_{rms}	2.2	4.3	5.3	1.9	3.8	5.3
		Nm	1.13	1.13	1.14	2.03	1.99	2.00
Peak Torque ⁸	T_{PK}	in-lb	10.0	10.0	10.1	18.0	17.7	17.7
		A_{rms}	6.6	12.8	16.0	5.8	11.3	15.9
Peak Current ⁸	$I_{PK(rms)}$	A_{rms}	6.6	12.8	16.0	5.8	11.3	15.9
Rated Speed ^{1,2,3,4}	S_r	rpm	4965	4965	4965	4965	4965	4965
		Nm	0.35	0.35	0.36	0.62	0.61	0.61
Rated Torque ^{1,2,3}	T_r	in-lb	3.1	3.1	3.2	5.5	5.4	5.4
		kW	0.18	0.18	0.19	0.32	0.32	0.32
Shaft Power @ Rated Speed ^{1,2,3}	P_{out}	kW	0.18	0.18	0.19	0.32	0.32	0.32
Current @ Rated Speed ^{1,2,3}	I_r	Arms	2.1	4.1	5.2	1.8	3.6	5.0
Voltage Constant ^{4,7}	K_e	$V_{rms}/krpm$	10.37	5.32	4.35	21.14	10.74	7.67
Torque Constant ^{4,7}	$K_t(sine)$	Nm/A_{rms}	0.17	0.09	0.07	0.35	0.18	0.13
Resistance ^{4,7}	R	ohm	4.57	1.22	0.79	6.97	1.86	0.94
Inductance ^{5,7}	L	mH	15.49	4.04	2.69	28.52	7.43	3.79
Max DC bus Voltage ⁶	V_{mbus}	VDC _{max}	340	340	340	340	340	340
Max AC Voltage ⁶	V_s	VAC	240	240	240	240	240	240
Rotor Inertia ⁶	J	kg-m ²	5.20 ⁻⁶	5.20 ⁻⁶	5.20 ⁻⁶	9.04 ⁻⁶	9.04 ⁻⁶	9.04 ⁻⁶
		in-lb-sec ²	4.60 ⁻⁵	4.60 ⁻⁵	4.60 ⁻⁵	8.00 ⁻⁵	8.00 ⁻⁵	8.00 ⁻⁵
Motor Weight ⁶		kg	0.67	0.67	0.67	0.92	0.92	0.92
		lb	1.48	1.48	1.48	2.02	2.02	2.02

Model Size	Symbol	Units	BE232D	BE232F	BE232G	BE233D	BE233F	BE233G
Stall Torque Continuous ^{1,2,3}	T_{CS}	Nm	1.10	1.08	1.07	1.45	1.48	1.45
		in-lb	9.8	9.5	9.5	12.8	13.1	12.9
Stall Current Continuous ^{1,2,3}	$I_{CS(rms)}$	A_{rms}	2.0	3.8	5.5	1.8	3.5	5.6
		Nm	3.34	3.26	3.25	4.38	4.47	4.39
Peak Torque	T_{PK}	in-lb	29.6	28.9	28.7	38.8	39.6	38.9
		A_{rms}	5.9	11.5	16.4	5.3	10.4	16.8
Peak Current	$I_{PK(rms)}$	A_{rms}	5.9	11.5	16.4	5.3	10.4	16.8
Rated Speed ^{1,2,3}	S_r	rpm	4965	4965	4965	3741	4965	4965
		Nm	0.99	0.96	0.96	1.33	1.29	1.27
Rated Torque ^{1,2,3}	T_r	in-lb	8.8	8.5	8.5	11.8	11.5	11.2
		kW	0.51	0.5	0.5	0.52	0.67	0.66
Shaft Power @ Rated Speed ^{1,2,3}	P_{out}	kW	0.51	0.5	0.5	0.52	0.67	0.66
Current @ Rated Speed ^{1,2,3}	I_r	Arms	1.8	3.5	5.0	1.6	3.1	5.0
Voltage Constant ^{4,7}	K_e	$V_{rms}/krpm$	34.14	17.18	12	50.42	26.19	15.85
Torque Constant ^{4,7}	$K_t(sine)$	Nm/A_{rms}	0.56	0.28	0.2	0.83	0.43	0.26
Resistance ^{4,7}	R	ohm	7.72	2.05	1.01	10.98	2.85	1.08
Inductance ^{5,7}	L	mH	35.8	9.66	4.73	51.71	13.95	5.02
Max DC bus Voltage ⁶	V_{mbus}	VDC _{max}	340	340	340	340	340	340
Max AC Voltage ⁶	V_s	VAC	240	240	240	240	240	240
Rotor Inertia ⁶	J	kg-m ²	1.70 ⁻⁵	1.70 ⁻⁵	1.70 ⁻⁵	2.37 ⁻⁵	2.37 ⁻⁵	2.37 ⁻⁵
		in-lb-sec ²	1.50 ⁻⁴	1.50 ⁻⁴	1.50 ⁻⁴	2.10 ⁻⁴	2.10 ⁻⁴	2.10 ⁻⁴
Motor Weight ⁶		kg	1.41	1.41	1.41	1.9	1.9	1.9
		lb	3.1	3.1	3.1	4.18	4.18	4.18

Note: These specifications are based on theoretical motor performance and are not specific to any amplifier.

¹ @ 25°C ambient, 125°C winding temperature, motor connected to a 10" x 10" x 1/4" aluminum mounting plate;

@ 40°C ambient derate phase currents and torques by 6%.

² Maximum winding temperature is 155 °C. Thermal protection device threshold may be at a lower temperature.

³ These ratings are valid for Parker drives. Other drives may not achieve the same ratings.

⁴ Maximum speed is 5000 RPM.

⁵ Measured line-to-line, ±10%. ±30%, line-to-line inductance bridge measurement @1Khz.

⁶ Reference only.

⁷ Total motor torque per peak of the sinusoidal amps measured in any phase, ±10%.

⁸ Initial winding temperature must be 60°C or less before peak current is applied.

⁹ Use servo drive thermal model for overtemp protection or lower peak current.

NEMA Size 23 Speed-Torque Performance

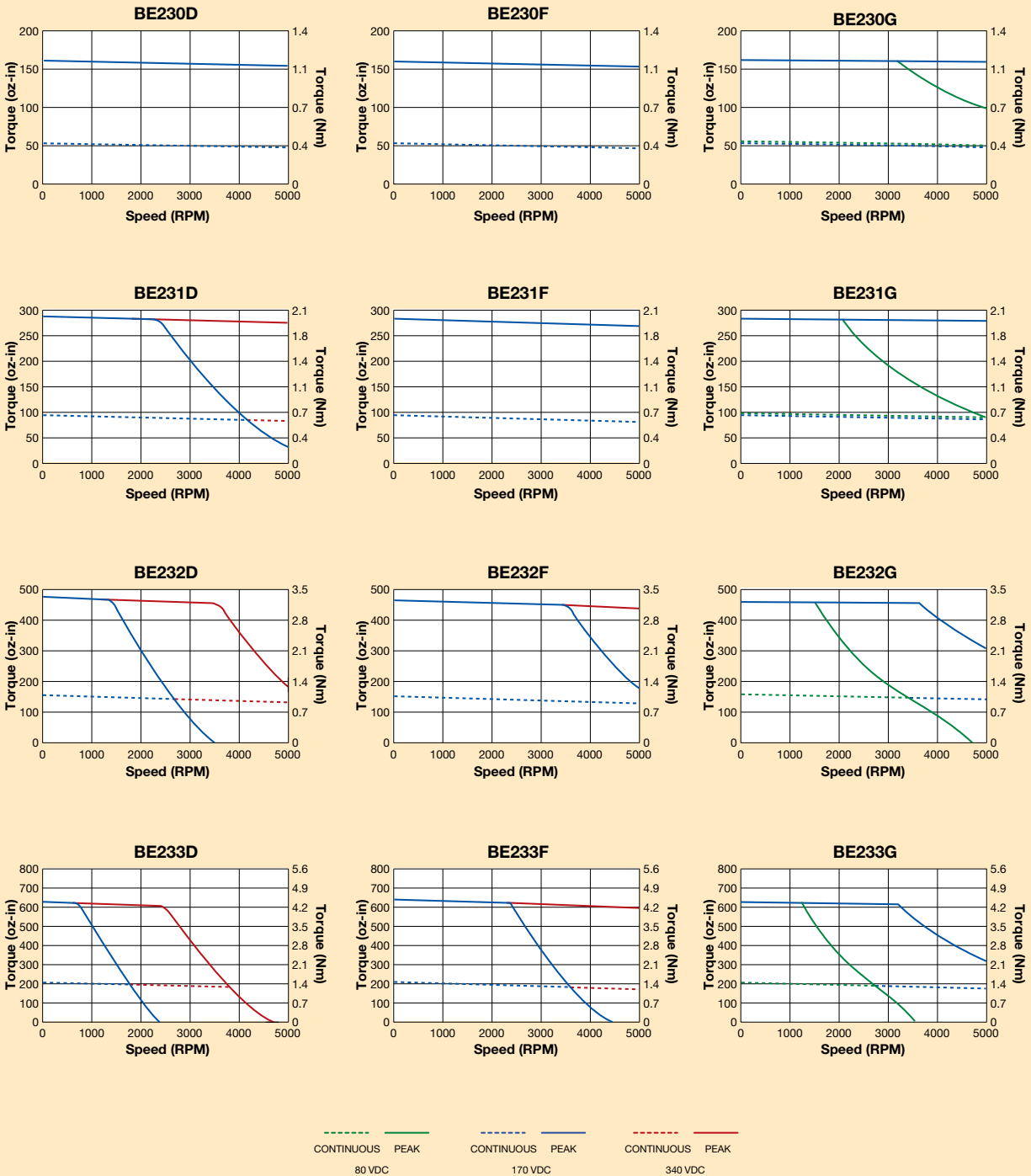

Note:

120 VAC input to drive is 170 VDC bus; 240 VAC input to drive is 340 VDC bus

For performance with different voltages and windings, see Parker Motion Sizer or Parker System Solution Finder software, free download available at www.parkermotion.com

BE Series Servo Motors

NEMA Size 34 Performance (Data at 240 VAC)

Model Size	Symbol	Units	BE341F	BE341G	BE341J	BE342H	BE342K
Stall Torque Continuous ^{1,2,3}	T_{cs}	Nm	1.69	1.66	1.68	2.85	2.88
		in-lb	14.9	14.7	14.8	25.2	25.5
Stall Current Continuous ^{1,2,3}	$I_{cs(rms)}$	A_{rms}	3.6	5.2	7.4	4.8	9.5
		Nm	5.09	5.00	5.05	8.58	8.69
Peak Torque ⁸	T_{pk}	in-lb	45.0	44.3	44.7	75.9	76.9
		A_{rms}	10.9	15.7	22.1	14.5	28.6
Peak Current ⁸	$I_{pk(rms)}$						
Rated Speed ^{1,2,3,4}	S_r	rpm	4965	4965	4965	4965	4965
Rated Torque ^{1,2,3}	T_r	Nm	1.44	1.42	1.43	2.34	2.37
		in-lb	12.8	12.6	12.7	20.7	21.0
Shaft Power @ Rated Speed ^{1,2,3}	P_{out}	kW	0.75	0.74	0.74	1.21	1.23
Current @ Rated Speed ^{1,2,3}	I_r	Arms	3.2	4.6	6.5	4.1	8.0
Voltage Constant ^{4,8}	K_e	V_{rms}/k_{rpm}	28.29	19.33	13.85	35.77	18.44
Torque Constant ^{4,8}	$K_{t(sine)}$	Nm/A_{rms}	0.47	0.32	0.23	0.59	0.30
Resistance ^{4,8}	R	ohm	2.59	1.25	0.63	1.70	0.44
Inductance ^{5,8}	L	mH	30.95	14.47	7.43	20.13	5.03
Max DC bus Voltage ⁶	V_{mbus}	VDC _{max}	340	340	340	340	340
Max AC Voltage ⁶	V_s	VAC	240	240	240	240	240
Rotor Inertia ⁶	J	kg-m2	3.05 ⁻⁵	3.05 ⁻⁵	3.05 ⁻⁵	4.97 ⁻⁵	4.97 ⁻⁵
		in-lb-sec ²	2.70 ⁻⁴	2.70 ⁻⁴	2.70 ⁻⁴	4.40 ⁻⁴	4.40 ⁻⁴
Motor Weight ⁶		kg	2.18	2.18	2.18	3.22	3.22
		lb	4.80	4.80	4.80	7.10	7.10

Model Size	Symbol	Units	BE343J	BE343L	BE344J	BE344L
Stall Torque Continuous ^{1,2,3}	T_{cs}	Nm	4.00	3.96	4.86	4.81
		in-lb	35.4	35.1	43.0	42.5
Stall Current Continuous ^{1,2,3}	$I_{cs(rms)}$	A_{rms}	7.0	11.2	6.4	10.1
		Nm	12.05	11.95	14.64	14.49
Peak Torque	T_{pk}	in-lb	106.7	105.8	129.5	128.3
		A_{rms}	21.1	33.5	19.2	30.4
Peak Current	$I_{pk(rms)}$					
Rated Speed ^{1,2,3}	S_r	rpm	4965	4965	2980	2980
Rated Torque ^{1,2,3}	T_r	Nm	3.08	3.05	4.33	4.29
		in-lb	27.3	27.0	38.3	37.9
Shaft Power @ Rated Speed ^{1,2,3}	P_{out}	kW	1.60	1.59	1.35	1.34
Current @ Rated Speed ^{1,2,3}	I_r	Arms	5.5	8.8	5.8	9.1
Voltage Constant ^{4,8}	K_e	V_{rms}/k_{rpm}	34.65	21.62	46.21	28.88
Torque Constant ^{4,8}	$K_{t(sine)}$	Nm/A_{rms}	0.57	0.36	0.76	0.48
Resistance ^{4,8}	R	ohm	0.96	0.38	1.23	0.49
Inductance ^{5,8}	L	mH	14.16	5.53	17.26	6.74
Max DC bus Voltage ⁶	V_{mbus}	VDC _{max}	340	340	340	340
Max AC Voltage ⁶	V_s	VAC	240	240	240	240
Rotor Inertia ⁶	J	kg-m2	6.89 ⁻⁵	6.89 ⁻⁵	8.70 ⁻⁵	8.70 ⁻⁵
		in-lb-sec ²	6.10 ⁻⁴	6.10 ⁻⁴	7.70 ⁻⁴	7.70 ⁻⁴
Motor Weight ⁶		kg	4.25	4.25	5.31	5.31
		lb	9.37	9.37	11.70	11.70

Note: These specifications are based on theoretical motor performance and are not specific to any amplifier.

¹ @ 25°C ambient, 125°C winding temperature, motor connected to a 10" x 10" x 1/4" aluminum mounting plate;

@ 40°C ambient derate phase currents and torques by 6%.

² Maximum winding temperature is 155 °C. Thermal protection device threshold may be at a lower temperature.

³ These ratings are valid for Parker drives. Other drives may not achieve the same ratings.

⁴ Maximum speed is 5000 RPM, except BE344 which is limited to 3000 RPM max speed.

⁵ Measured line-to-line, ±10%. ±30%, line-to-line inductance bridge measurement @1KHz.

⁶ Reference only.

⁷ Total motor torque per peak of the sinusoidal amps measured in any phase, ±10%.

⁸ Initial winding temperature must be 60°C or less before peak current is applied.

⁹ Use servo drive thermal model for overtemp protection or lower peak current.

NEMA Size 34 Speed-Torque Performance

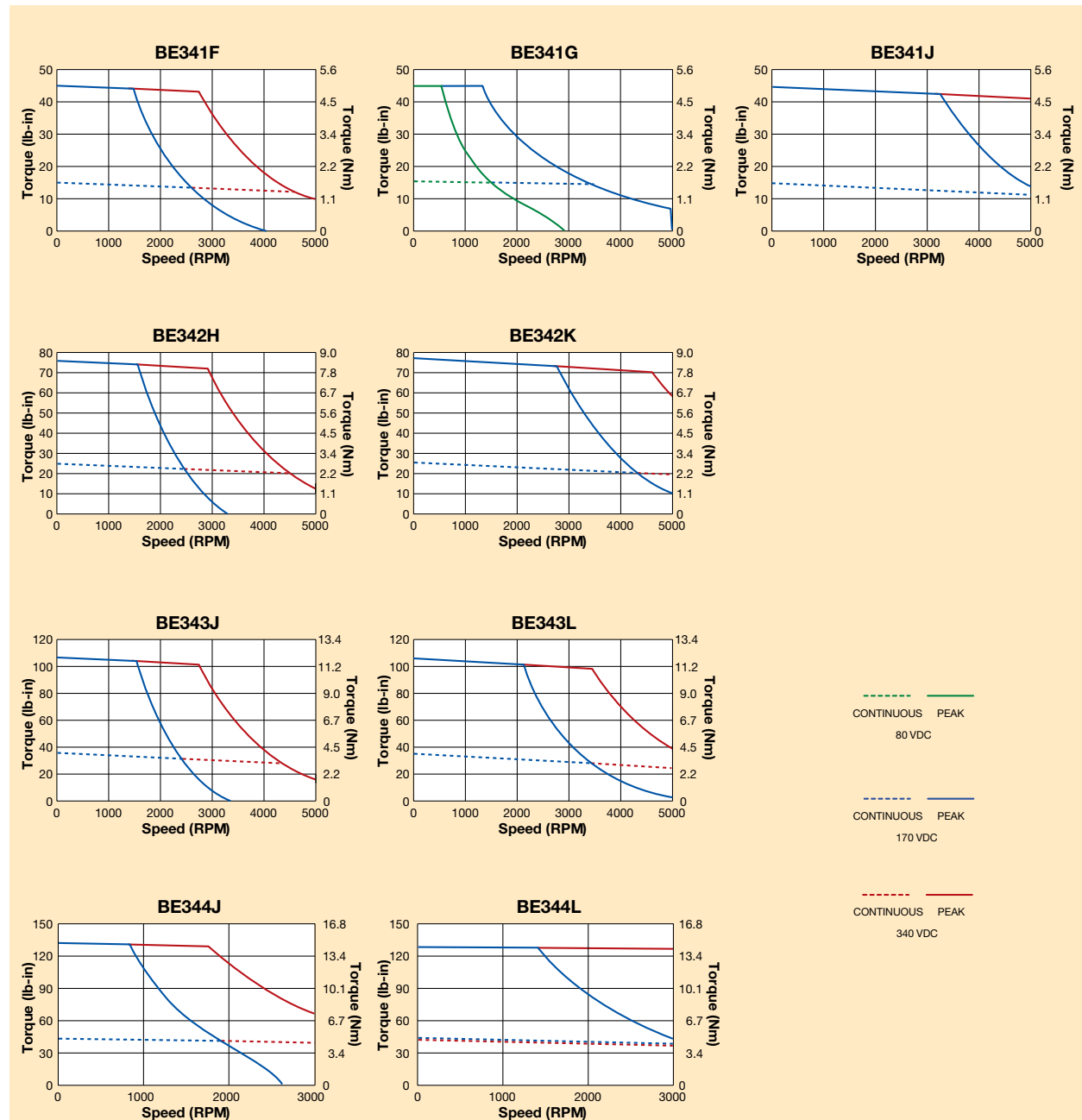

Note:

120 VAC input to drive is 170 VDC bus; 240 VAC input to drive is 340 VDC bus

For performance with different voltages and windings, see Parker Motion Sizer or Parker System Solution Finder software, free download available at www.parkermotion.com

BE Series Servo Motors



Dimensions — NEMA Size 16

See pages 12-17 for cable and connector details

Inches (mm)

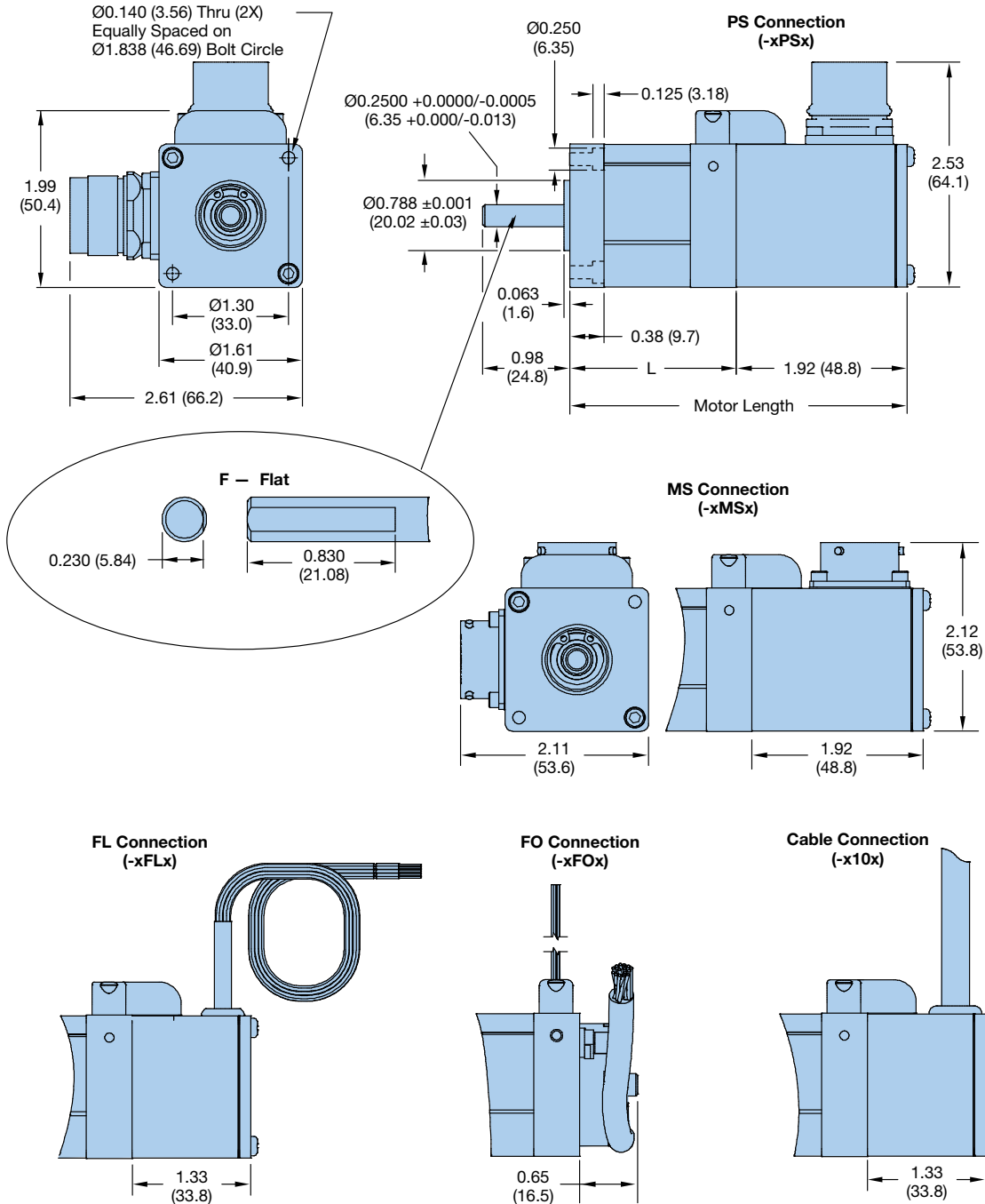

Motor Size	Dimension "L"	Motor Length (by Connection Type)		
		PS, MS	FL, Cable	FO
BE161	1.37 (34.7)	3.29 (83.5)	2.70 (68.5)	2.02 (51.3)
BE162	1.87 (47.4)	3.79 (96.2)	3.20 (81.2)	2.52 (64.0)
BE163	2.37 (60.1)	4.29 (108.9)	3.70 (93.9)	3.02 (76.7)
BE164	2.87 (72.8)	4.79 (121.6)	4.20 (106.6)	3.52 (89.4)

Dimensions — NEMA Size 23

See pages 12-17 for cable and connector details

Inches (mm)

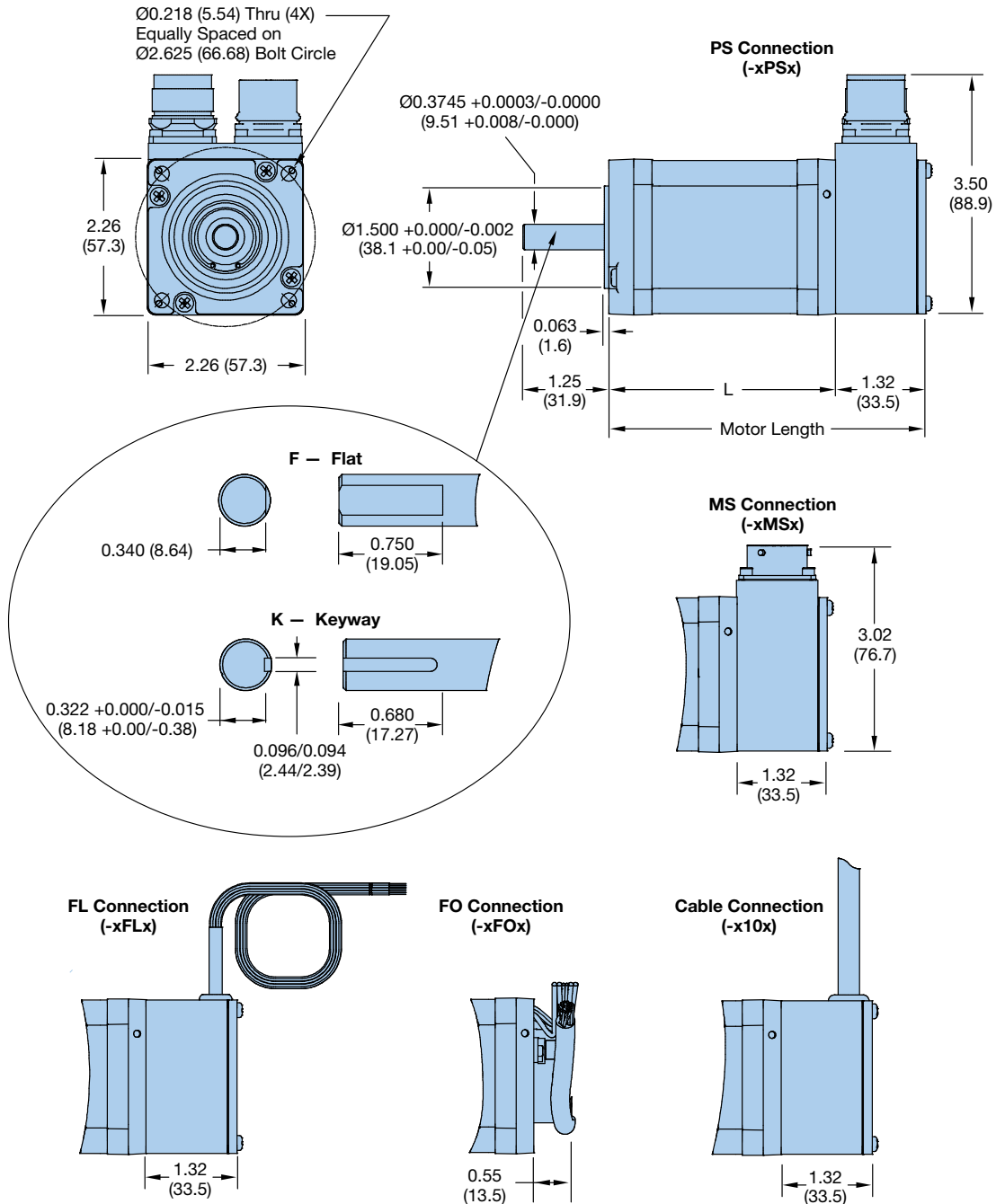

Motor Size	Dimension "L"		Motor Length (by Connection Type)*	
	Without Brake	With Brake	PS, MS, FL, Cable	FO
BE230	1.82 (46.2)	3.89 (98.9)	3.14 (79.7)	2.37 (60.1)
BE231	2.32 (58.9)	4.39 (111.5)	3.64 (92.4)	2.87 (72.8)
BE232	3.32 (84.3)	5.39 (137.0)	4.64 (117.8)	3.87 (98.2)
BE233	4.32 (109.7)	6.39 (175.3)	5.64 (143.2)	4.87 (123.6)

Motor length with brake adds 1.31 in (33.3 mm) to motor length. BE23 brake option is available as custom order only. Consult factory.

BE Series Servo Motors



Dimensions — NEMA Size 34

See pages 12-17 for cable and connector details

Inches (mm)

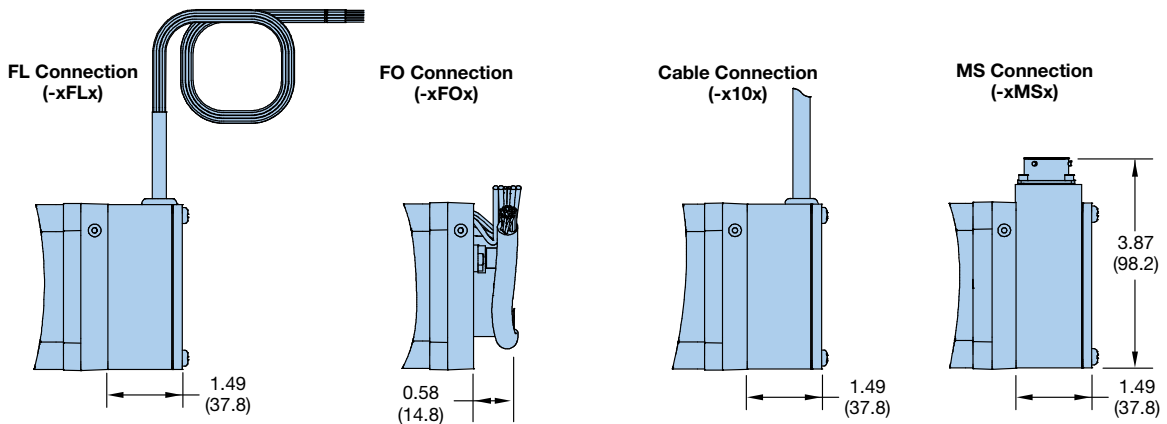
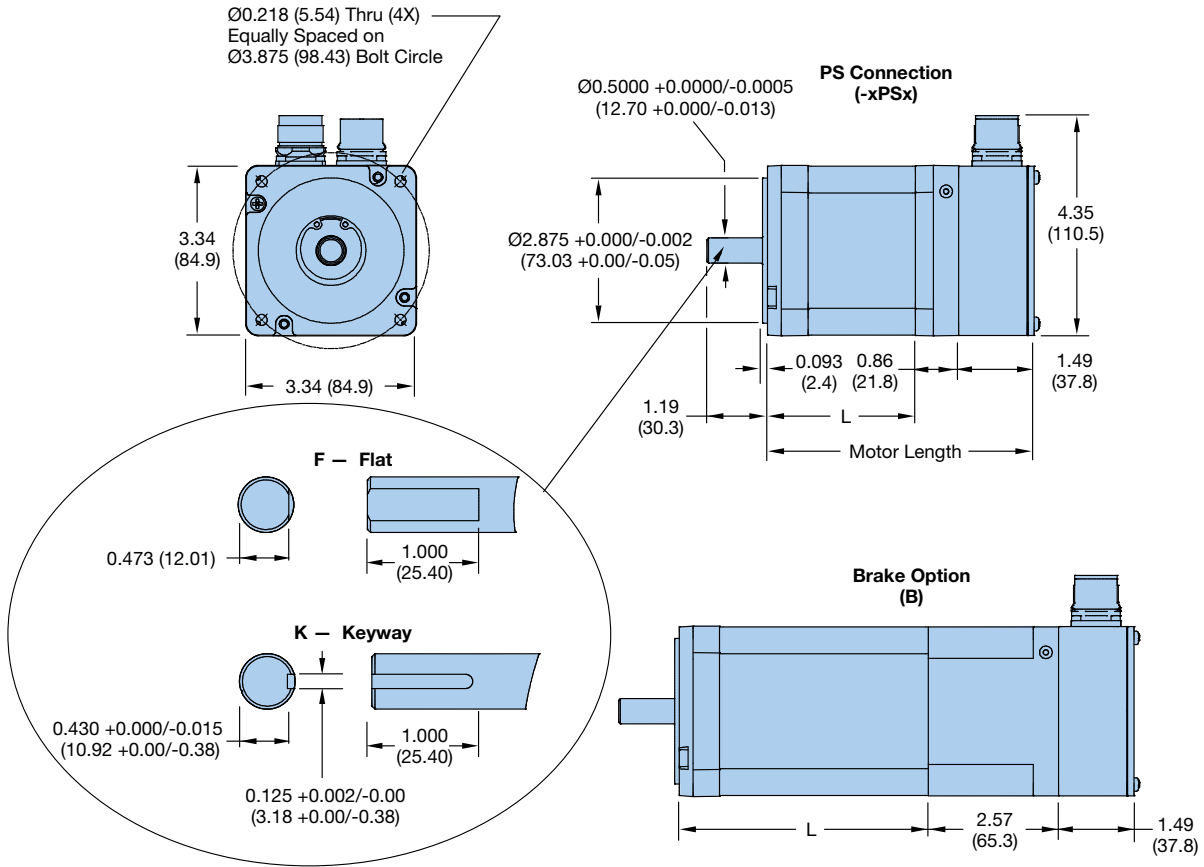

Motor Size	Dimension "L"	Motor Length (by Connection Type)			
		PS, MS, FL, Cable		FO	
		Without Brake	With Brake Option	Without Brake	With Brake Option
BE341	1.92 (48.8)	4.27 (108.4)	5.98 (151.8)	3.36 (85.3)	5.07 (128.7)
BE342	2.92 (74.2)	5.27 (133.8)	6.98 (177.2)	4.36 (110.7)	6.07 (154.1)
BE343	3.92 (99.6)	6.27 (159.2)	7.98 (202.6)	5.36 (136.1)	7.07 (179.5)
BE344	4.92 (125.0)	7.27 (184.6)	8.98 (228.0)	6.36 (161.5)	8.07 (204.9)

Recommended Parker Drives for BE Series Motor

Frame Size	BE Model Size	Aries	Compax3	ViX
NEMA 16	BE161C	AR04xE	S025V2	ViX250AE or ViX250IE
	BE162C	AR04xE	S025V2	ViX250AE or ViX250IE
	BE163C	AR04xE	S025V2	ViX250AE or ViX250IE
	BE163D	—	—	ViX500AE or ViX500IE
	BE164C	AR04xE	S025V2	
	BE164F	—	—	ViX500AE or ViX500IE
	BE164Z	AR02xE	S025V2	—
NEMA 23	BE230D	AR04xE	S025V2	—
	BE230G	—	—	ViX500AE or ViX500IE
	BE231D	AR04xE	S025V2	—
	BE231F	AR08xE	S063V2	—
	BE231G	—	—	ViX500AE or ViX500IE
	BE232D	AR08xE	S025V2	—
	BE232F	AR08xE	S063V2	—
	BE232G	—	—	ViX500AE or ViX500IE
	BE233D	AR08xE	S025V2	—
	BE233F	AR08xE	S063V2	—
BE233G	—	—	ViX500AE or ViX500IE	
NEMA 23	BE341F	AR08xE	S063V2	
	BE341G	—	—	ViX500AE or ViX500IE
	BE341J	AR20AE	S100V2	—
	BE342H	AR13xE	S063V2	—
	BE342K	AR20AE	S100V2	—
	BE343J	AR20AE	S100V2	—
	BE343L	AR30AE	S150V2	—
	BE344J	AR13xE	S063V2	—
BE344L	AR20AE	S100V2	—	

BE Series Servo Motors

Cable Options

Include length to complete power cable part number:

XX = Cable Length (ft)

For example, 05 = 5 ft

Stock Lengths: 10, 25, 50 feet

Non-Stock Lengths: 5, 15, 20, 30, 35, 40 and 45 feet

Power Cables*

BE Model Size	BE Pin Connector Type	
	PS*	MS
BE16 (all models)	P-1A1-XX	71-018304-XX
BE23 (all models)	P-1A1-XX	71-018304-XX
BE341F	P-1A1-XX	71-018304-XX
BE341G	P-1A1-XX	71-018304-XX
BE342H	P-1A1-XX	71-018304-XX
BE341J	P-3B1-XX	71-018304-XX
BE342K	P-3B1-XX	71-018304-XX
BE343J	P-3B1-XX	71-018304-XX
BE343L	P-3B1-XX	71-018305-XX
BE344J	P-3B1-XX	71-018304-XX
BE344L	P-3B1-XX	71-018305-XX

* All power cables have flying lead ends. All PS connector type power cables include brake leads, whether or not the motor has a brake.

Feedback Cables (with Parker drive-compatible terminations)

Feedback Option	BE Pin Connector Type with Drive Compatible Termination				
	PS			MS (No Brake)	MS (w/Brake)
	Aries/ViX	Compax3	Gemini	Gemini	Gemini
J 2000 line Incremental Encoder	F-1A1-XX	F-2C1-XX	F-3C1-XX	71-018308-XX	71-018309-XX
L 5000 line Incremental Encoder	F-1A1-XX	F-2C1-XX	F-3C1-XX	71-018308-XX	71-018309-XX
Q Serial Encoder	F-1A1-XX	—	—	—	—
R Resolver	F-1A1-XX	F-2B1-XX	F-3D1-XX	71-018307-XX	71-018307-XX

Feedback Cables (with pin connector one end and flying leads)

PS Connector	F-9F1-XX
MS with Encoder*	71-015871-XX
MS with Resolver*	71-015870-XX

*Include brake leads, whether or not the motor has a brake.

Feedback Options

Resolver Schematic

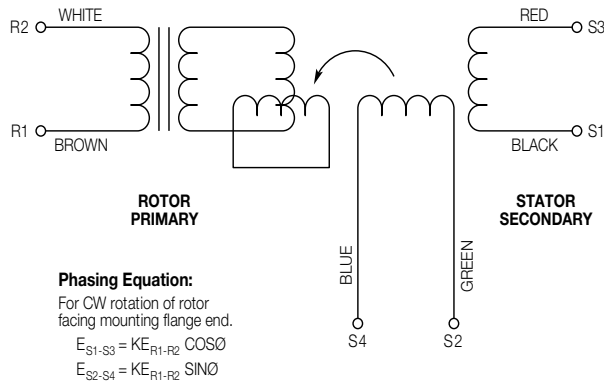

Resolver Specifications

Parameter	Value
Input	
Voltage @ 7 kHz	4.25 volts
Current, max	55 mA
Power, nom	0.12 watts
Impedance	
ZSO*	58+j145 ohms
ZRO	53+j72 ohms
ZRS	42+j55 ohms
ZSS	50+j128 ohms
Transformation Ratio	0.470 ±5%
Output Voltage	2.0 ±5% volts
DC Resistance	
Rotor	23 ±10% ohms
Stator	19 ±10% ohms
Sensitivity	35 mV/°
Max Error from EZ	±10 minutes
Phase Shift, Open Circuit	5° leading, ±3"
Null Voltage, total	20 mV rms
Inertia	See motor specification

* @ 90°C

Encoder Specifications

Parameter	Value
Mechanical Accuracy	±2 min of arc
Electrical	
Input Power	5 VDC ±10%, 108 mA
Operating Frequency	500 kHz max
Output Device	AM26C31DBR
Sink/Source, nom	20 mA
Suggested User Interface	26LS32

Hall-Effect Specifications

Parameter	Value
Mechanical Accuracy	±2 min of arc
Electrical	
Input Power	5 VDC ±10%, 80 mA
Output Device, Open Collector	LM339
Sink	4 mA

Commutation Chart

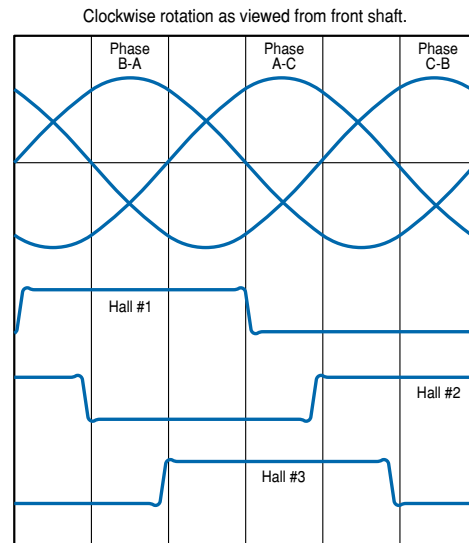

Electrically-Released Brake Option

	Size 23	Size 34
Static rated torque – Nm (lb-in)	1.13 (10)	4.18 (37)
Coil voltage – VDC	24	24
Coil current – amps	0.38	0.50
Weight – kg (lbs)	0.3 (0.7)	1 (2.2)
Inertia – kg-m² (lb-in-sec²)	0.000002 (0.000018)	0.00001 (0.00009)
Engage/Disengage Time – msec	20/10	20/40

BE Series Servo Motors

PS Option – Parker Standard (-xPSx) Pin Connections

The PS connector option for the BE motors features high-quality Hypertac - Interconnectron circular connectors mounted to the motor body.

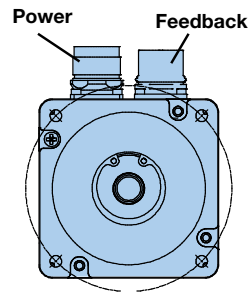

Mating cables are specified and ordered separately. The PS option joins the motor phase wires and brake leads into one connector. The second connector has motor feedback signals, hall effect signals, and thermistor signals. The Parker standard connectors are rated to IP65.

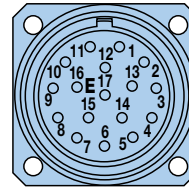

Feedback

Feedback Connector
PN: 43-025367-01

Mating Connector
PN: 43-021660-01

PS Resolver (R) Pin Connections

Designation	Motor Feedback Pin Connector #
Sin+	2
Sin-	1
Cos+	11
Cos-	12
Ref+	14
Ref-	17
Temp	9
Temp	13

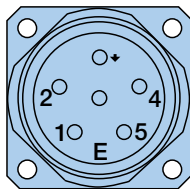

Power

Size 1.0 Power Connector
PN: 43-024091-01

Mating Connector
PN: 43-021659-01

PS Incremental Encoder/Hall (J, L and Q) Pin Connections

Designation (Smart Encoder)	Motor Feedback Pin Connector #
Vcc	8
Gnd	7
CH A+	2
CH A-	1
CH B+	11
CH B-	12
Index + (or Data +)	15
Index - (or Data -)	16
Temp	13
Temp	9
Hall Gnd (NA for Q, 3E)	7
Hall +5V (NA for Q, 3E)	8
Hall 1 (or CLK +)	4
Hall 2 (or CLK -)	5
Hall 3 (NA for Q, 3E)	6

PS Power & Brake Pin Connections

Designation	1.0 Motor Power Pin Connector #	1.5 Motor Power Pin Connector #
Phase A	1	U
Phase B	2	V
Phase C	6	W
Gnd	3	⊥
Shield	3	⊥
Brake	4	+
Brake	5	-

NOTE: For customers preferring to build their own mating cables, a PS connector kit (Part #: PS-CONN-KIT), is available. The kit contains a mating PS power connector, PS feedback connector and connector pins, allowing customers to build cables to their own specification. Special tools are not included in the kit.

MS Option – Military Style (-xMSx) Pin Connections

The “MS” connection option for the BE Series motors provides quick disconnect, bayonet style connectors attached to the motor body.

Mating cables are specified and ordered separately.

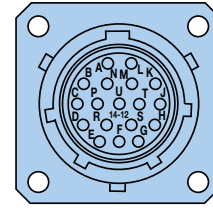
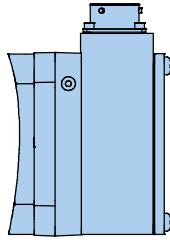

Feedback

With the “MS” connection option, the motor phase wires are in one connector, and the hall, encoder, temperature switch, and brake wires are in the other connector. This option works well when using an amplifier with a built-in controller, or when all cables enter into a cabinet or enclosure and then are wired into a terminal strip.

When specifying the “R” (resolver) feedback option, the motor phase wires reside in one connector, the resolver signal, temperature switch, and brake wires in the other.

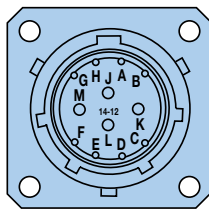

Power

MS Power Pin Connections

Designation	Motor Power Pin Connector Letter
Phase A	J
Phase B	K
Phase C	L
Gnd	M
Temp*	G
Temp*	H

* BE with MS connectors: Temp leads in feedback connector

MS Resolver and Brake (R) Pin Connections

Designation	Motor Feedback Pin Connector Letter
Sin+	L
Sin-	G
Cos+	E
Cos-	J
Ref+	C
Ref-	U
Brake	S
Brake	T
Temp	R
Temp	N

MS Incremental Encoder/Hall and Brake (J and L) Pin Connections

Designation (Smart Encoder)	Motor Feedback Pin Connector Letter
Vcc	H
Gnd	G
CH A+	A
CH A-	B
CH B+	C
CH B-	D
Index + (or Data +)	E
Index - (or Data -)	F
Temp*	L
Temp*	N
Brake	R
Brake	S
Hall Gnd	K
Hall +5V	M
Hall 1 (or CLK +)	T
Hall 2 (or CLK -)	U
Hall 3	P

BE Series Servo Motors

Wiring Connections for:

FL Option – Flying Leads with Enclosed Feedback (-xFLx)

FO Option – Flying Leads with Exposed Feedback (-xFOx)

10 Option – 10' Cable (-x10x)

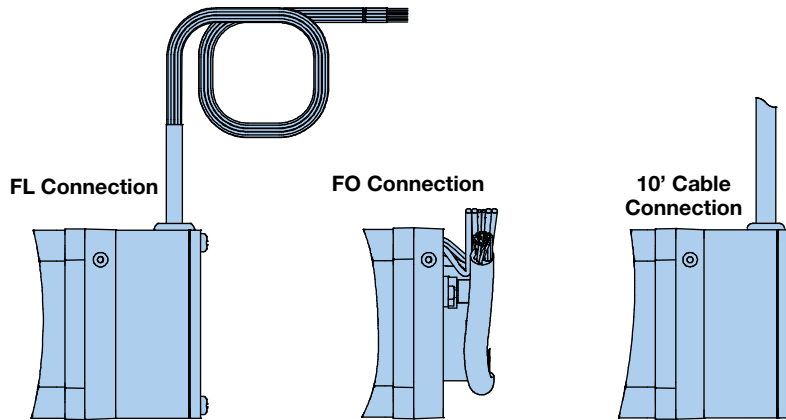

FO/FL Flying Leads

The FO/FL cable option for the BE motors features 18" flying leads for both feedback and power connections. The only variable is whether or not the feedback device is fully enclosed (FL) or fully exposed (FO).

These options are for OEM customers that wish to reduce cost as much as possible and fully integrate their own cable solutions.

10 - 10' hard wired cable

The 10' cable option for the BE motors uses the standard Parker cable hard wired into the rear of the motor. The cables have full strain relief and completely enclosed feedback. While custom lengths are available, it is not recommended to exceed 10 feet between motor and drive.

Motor Power Leads

Designation	Wire Color (FL/FO and 10' Cable)
Phase A	Red/Yellow
Phase B	White/Yellow
Phase C	Black/Yellow
Gnd	Green/Yellow
Temp	Yellow/Orange
Temp	Yellow/Orange

Feedback and Brake (J) Leads

Designation	Wire Color	
	FL, FO	10'
Vcc	Red	Red
Gnd	Black & Black/White	Black & Red/Blue
CH A +	Yellow	Yellow/Brown
CH A -	Yellow/White	White/Yellow
CH B +	Blue	Brown
CH B -	Blue/White	White
Index +	Orange	Green
Index -	Orange/White	Yellow
Brake	Red/Blue	Gray/Brown
Brake	Red/Blue	White/Gray
Temp +	—	Pink/Brown
Temp -	—	White/Pink
Hall Gnd	Green/White	Blue
Hall +5V	Brown/White	Violet
Hall 1	Brown	White/Green
Hall 2	Green	Brown/Green
Hall 3	Violet	Gray/Pink

Ordering Information

Fill in an order code from each of the numbered fields to create a complete model order code.

①
 ②
 ③
 ④
 ⑤
 ⑥
 ⑦
 ⑧

Order Example: **BE** **16** **2** **D** **J** **-** **N** **10** **N**

- | | |
|--|--|
| <p>① Series
 BE Brushless Servo Motors</p> <p>② Frame Size
 16 NEMA Size 16 frame
 23 NEMA Size 23 frame
 34 NEMA Size 34 frame</p> <p>③ Stack Configuration
 0 1/2 stack magnet (NEMA 23 only)
 1 1 stack magnet
 2 2 stack magnet
 3 3 stack magnet
 4 4 stack magnet (NEMA 16 and 34 only)</p> <p>④ Winding*
 C NEMA 16 only
 Z NEMA 16 only
 D NEMA 16 and 23 only
 F All
 G NEMA 23 and 34 only
 H NEMA 34 only
 J NEMA 34 only
 K NEMA 34 only
 L NEMA 34 only</p> | <p>⑤ Feedback*
 J 2000 line encoder (8000 ppr post-quadrature)
 L 5000 line encoder (2000 ppr post-quadrature) (available with PS and MS connectors only)
 Q 2000 PPR Smart Encoder, Aries Only. No Halls.
 R Resolver
 <small>* Not all feedback devices are compatible with all connector options.</small></p> <p>⑥ Shaft Options
 N Round shaft
 F Flat
 K Keyway (not available on NEMA 16)</p> <p>⑦ Connector Options
 PS Parker standard connectors, all feedback options
 10 10 ft. cable
 FL Flying leads, 18" (housed feedback)
 FO Flying leads, 18" (exposed feedback)
 MS Military style</p> <p>⑧ Options
 N None
 B Brake (NEMA 23 and 34 only)</p> |
|--|--|

* Select based on appropriate performance characteristics, see pages 2-7)

Need more torque? Use a Parker gearhead!

Gearhead Advantages

- **Multiply torque allowing smaller motors (and drives) to be used, saving \$\$**
- **Reduce the reflected inertial load to the motor, making it easier to tune and increase stiffness and stability**
- **Have high sideload capacity**
- **Increase low speed smoothness**
- **Shorten inline length with right-angle gearheads**



Parker Gen II Stealth® gearheads are designed with helical planetary gears that provide low backlash, high-stiffness, high torque and long life. Stealth gearheads are ideal for high performance applications.

Parker PV series gearheads are standard-grade gearheads with high sideload capacity and the power of a planetary gearhead in a cost-effective solution.



BE Series:
Made in the USA

© 2013 Parker Hannifin Corporation
BRO-BE-0412

Issue Date 1.25.13



北京润诚时代科技有限公司

自动化事业部

地址：北京市朝阳区汤立路218号C座968室

邮编：100012

电话：010-84450370

传真：010-84450371

网址：www.runcheng.net

